



CHILISIN ELECTRONICS CORP.

SPECIFICATION FOR APPROVAL

CUSTOMER : _____
 CUSTOMER P/N : _____
 OUR DWG No : _____
 QUANTITY : _____ Pcs. DATE : 2005/02/15
 ITEM : BPF2520T2450HA1

SPECIFICATION ACCEPTED BY:	
COMPONENT ENGINEER	
ELECTRICAL ENGINEER	
MECHANICAL ENGINEER	
APPROVED	
REJECTED	

<p>奇力新電子股份有限公司 CHILISIN ELECTRONICS CORP. NO.29,LANE 301,TEHHSIN ROAD,HUKOU, HSINCHU,TAIWAN,303, REPUBLIC OF CHINA TEL : (03) 599-2646 FAX : (03) 599-9176 E-mail : taiwan@chilisin.com.tw http : //www.chilisin.com.tw 台北營業處 TAIPEI OFFICE 3F,NO.233-1,PAO-CHIAO ROAD, HSIN TIEN,TAIPEI,TAIWAN, R.O.C. TEL : (02)29112073 FAX : (02)29147698 E-mail : taipei@chilisin.com.tw</p>	<p>東莞奇力新電子有限公司 DONG GUANG CHILISIN ELECTRONICS LTD. YULIANGWEI ADMINISTRATION AREA, QINGXI TOWN, DONGGUANG,GUANGDONG, CHINA TEL : 00286769-7730251~3 FAX : 00286769-7730232 E-mail : cect@chilisin.com.tw 奇力新電子(蘇州)有限公司 CHILISIN ELECTRONICS(SUZHOU)CO.,LTD NO.10, Zhu Yuan Road, Suzhou New District, Suzhou,P.R.C. TEL : 00286512-8255568 FAX : 00286512-8255568 E-mail : chilisin.suzhou@yageo.com.tw</p>
--	--

DRAWN BY	CHECKED BY	APPROVED BY
----------	------------	-------------

BPF2520T2450HA1 Specification

1 Scope: This specification applies to WLAN , Bluetooth

2 Part Numbering: Product Identification

BPF 2520 T 2450 HA 1

(1) (2) (3) (4) (5) (6)

(1) Product Code:

Ex: BPF=Band Pass Filter

LPF =Low Pass Filter

(2) Series Dimension and Impedance:

Ex: 2520= 2.5mm*2.0mm , Impedance:50

(3) Packing :

Ex: T=Taping , B=Bulk

(4) Central Frequency:

Ex: 2450=2.45GHz

(5) Material Code:

(6) Internal Code:

Ex: 1=First version , 2=Second version

3 Rating:

Operating Temperature: - 25 85

4 Marking:

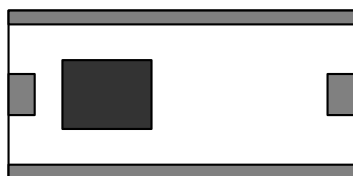

BPF2520T2450HA1 Specification

5 Configuration and Dimensions:

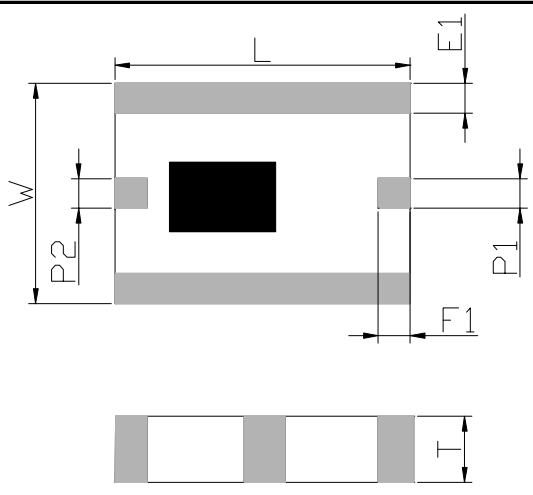
Figure	Dimension		Port
	L	2.5±0.15 mm	---
	W	2.0±0.15 mm	---
	T	0.75±0.15 mm	---
	P1	0.6±0.2 mm	I/O Termination
	P2	0.6±0.2 mm	I/O Termination
	E1	0.3±0.15 mm	GND
	F1	0.3±0.15 mm	---

6 Applications

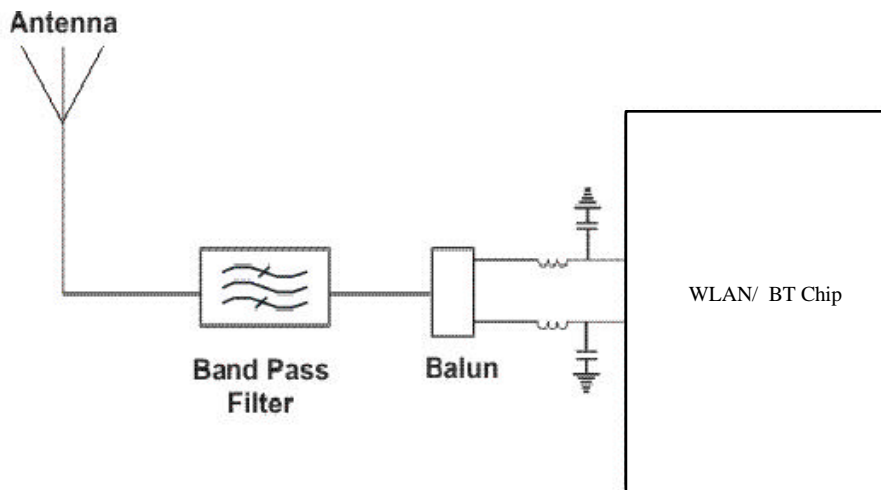

BPF2520T2450HA1 Specification

7 ELECTRICAL CHARACTERISTICS :

Pass Band	2400-2500 MHz
Impedance	50 ohm
Insertion Loss	1.5dB (Max) at 25 °C 1.8dB(Max) at -40 ~ +85 °C
Ripple	0.6dB
V.S.W.R.	2.0 (Max)
Attenuation	40dB Min @ 880~960MHz 50dB Min @ 1200MHz 30dB Min @ 1710~1785MHz 25dB Min @ 1850~1910MHz 30dB Min @ 4800~5000MHz
Dimension	2.5 x 2.0 x 0.75 mm

Tr1 S21 Log Mag 10.00dB/ Ref -20.00dB [F2]
Tr2 S11 Log Mag 10.00dB/ Ref 0.00dB [F2]

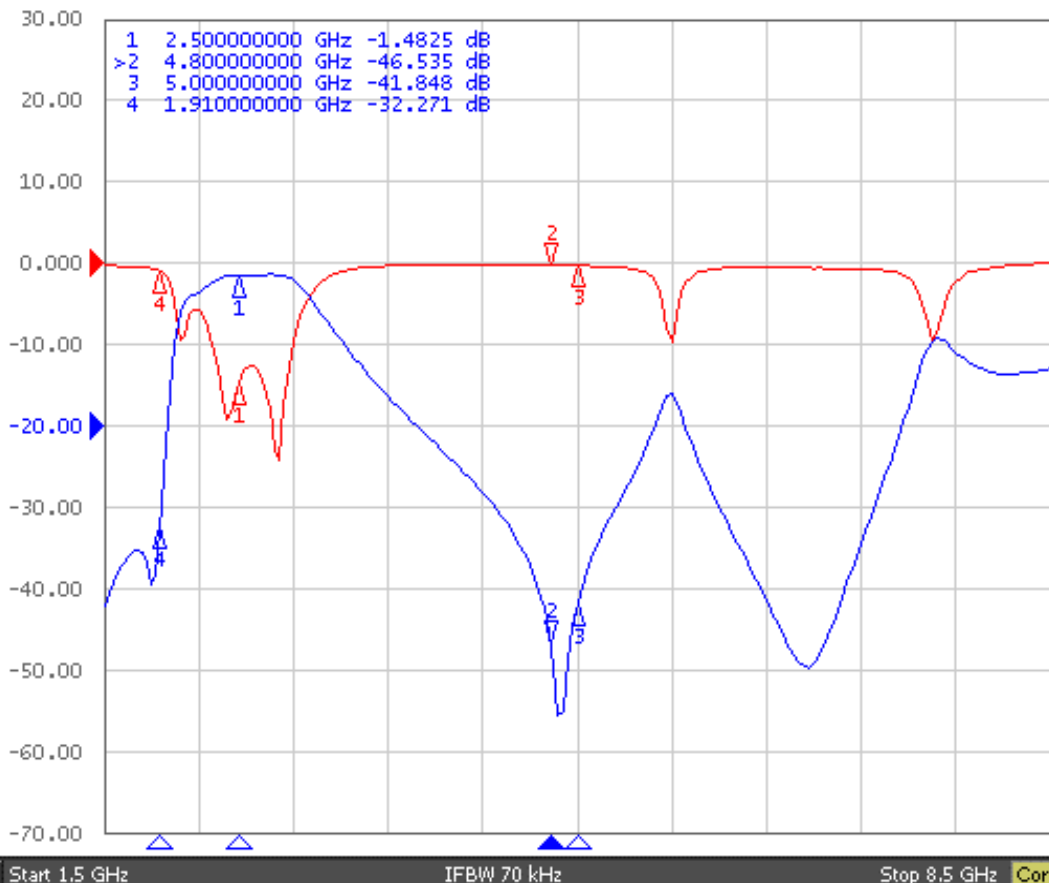



BPF2520T2450HA1 Specification

8

Reliability Data (Reference to IEC Specification)

IEC384-10/ CECC32100 CLAUSE	IEC60068-2 TEST METHOD	TEST	PROCEDURE	REQUIREMENTS
1-1		Mounting	The filter can be mounted on printedcircuit boards or ceramic substrates by applying wave soldering,reflow soldering (including vapour phase soldering) or conductive	No visible damage
1-2		Visual inspection and dimension check	Any applicable method using*10 magnification	In accordance with specification (chip off 1 mm)
1-3-1		Filter	VSWR < 2 at 20	Standard test board
1-4		Adhesion	A force of 3 N applied for 10 s to the line joining the terminations and in a plane parallel to the substrate	No visible damage
1-5		Bond strength of plating on end face	Mounted in accordance with CECC 32 100,paragraph 4.4	No visible damage
			Conditions: bending 0.5 mm at a rate of 1 mm/s,radius jig.340mm, 2mm warp on FR4 board of 90mm length	No visible damage
1-6	20(Tb)	Resistance to soldering heat	260 ± 5 for 10 ± 0.5 s in a static solder bath	No visible damage and complies with electrical performance
			260 ± 5 for 30 ± 1.0 s in a static solder bath	Using visual enlargement of *10 dissolution of the termination shall not exceed 10%



Qs 9000 Certificate

CHILISIN ELECTRONICS CORP.

BPF2520T2450HA1 Specification

8 Reliability Data (Reference to IEC Specication)

IEC384-10/ CECC32100 CLAUSE	IEC60068-2 TEST METHOD	TEST	PROCEDURE	REQUIREMENTS
1-7	20(Ta)	Solderability	Zero hour test, and test after storage(20 to 24months) in original atmosphere; un-mounted chips completely immersed for 2 ± 0.5 s in 235 ± 5 .	Th termination must be well tinned, at least 75% is well tinned at termination
1-8	4(Na)	Rapid change of temperature	-40 (30 minutes) to + 85 (30 minutes); 200 cycles	No visible damage and complies with electrical performance
1-9	IEC 60384-10	Climate sequence	1.Initial measurement 2.Dry Heat(16hours,85deg.C) 3.Damp heat,cycle,Test Db first cycle(24hours;55deg.C;95 to 100% R.H.) 4.Cold(-20deg.C,2hours) 5.Damp heat,cycle,Test Db, remaining 6.Final measurements	No visible damage and complies with electrical performance
1-10	3(Ca)	Damp heat	500 ± 12 hours at 40 ; 90 to 95 % RH	No visible damage and complies with electrical performance
1-11		Endurance	500 ± 12 hours at 85 ;	No visible damage and complies with electrical performance

BPF2520T2450HA1 Specification

9 PACKAGING

9.1 Packaging -Cover tape

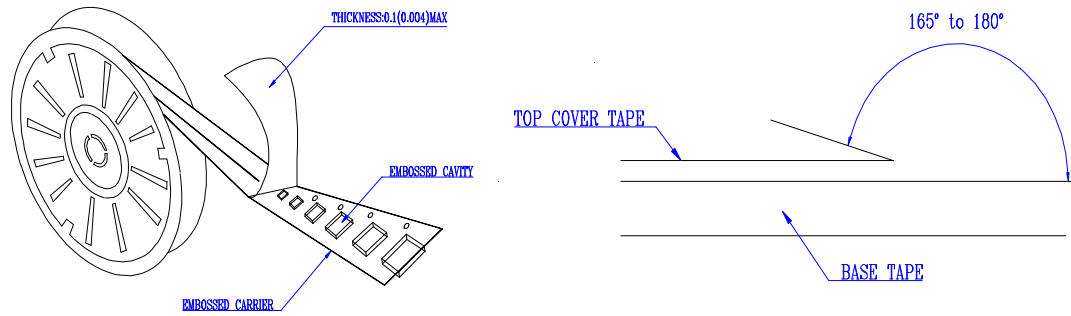

The force for tearing off cover tape is 10 to 60 grams in the arrow direction.

9.2 Packaging Quantity

TYPE	BULK	PCS/REEL
BPF2520	✓	3000

9.3 Reel Dimensions

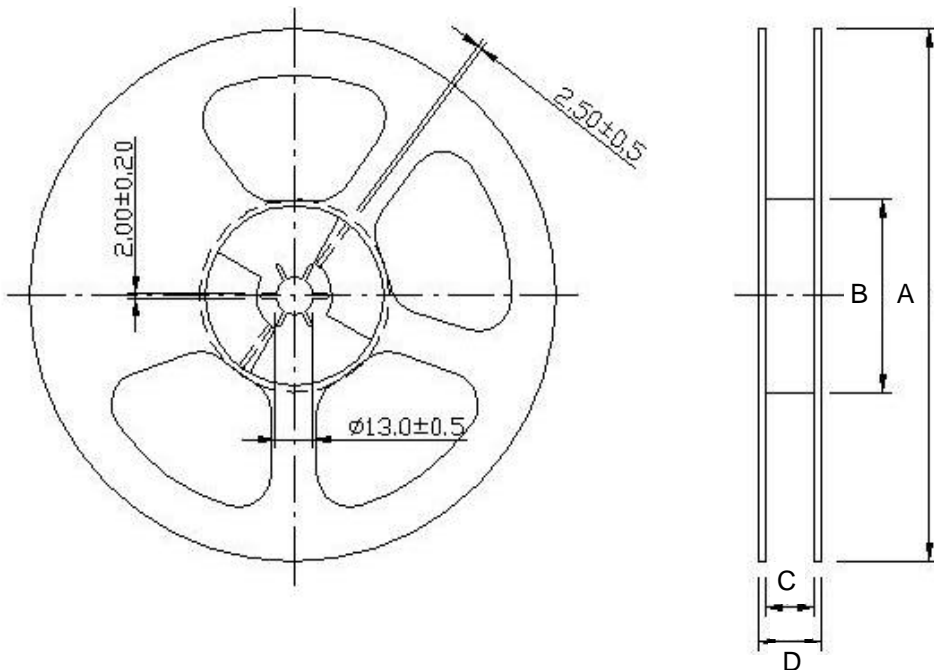

TYPE	A	B	C	D
BPF2520	178±1	62±1.5	8.4 ^{+0.15} ₋₀	14.4 max

BPF2520T2450HA1 Specification

9

PACKAGING

9.4

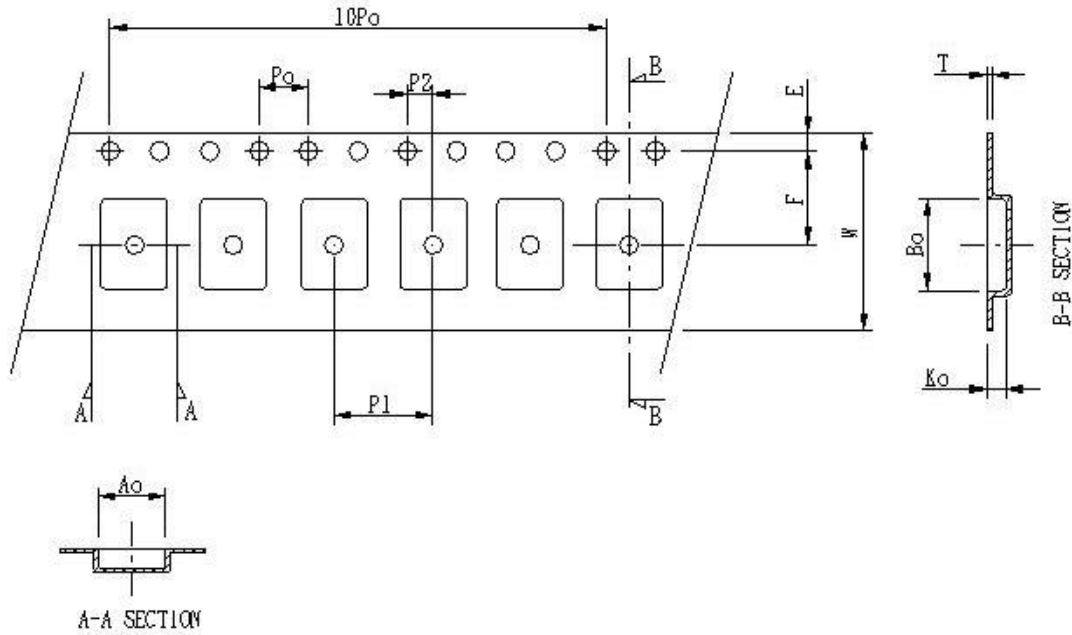

Serial no	Checking note	Index	Spec(mm)
1	Sprocket hole	D_o	1.50 ± 0.10
2	Pocket hole	D_1	$=1$
3	Distance sprocket hole/sprocket hole	P_o	4.0 ± 0.10
4	Distance pocket/pocket	P_1	4.0 ± 0.10
5	Distance sprocket hole/pocket	P_2	2.0 ± 0.10
6	Tape width	W	8.1 ± 0.20
7	Distance sprocket hole/outside	E	1.75 ± 0.10
8	Distance sprocket hole/pocket	F	3.5 ± 0.05
9	Pocket length nominal clearance	A_o	2.23 ± 0.10
10	Pocket length nominal clearance	B_o	2.72 ± 0.10
11	Pocket depth minimum clearance	K_o	1.15 ± 0.10
12	Thickness of tape	T	0.22 ± 0.05
13	10x sprocket hole pitch	$10P_o$	40.0 ± 0.20

BPF2520T2450HA1 Specification

10 Recommended Pattern

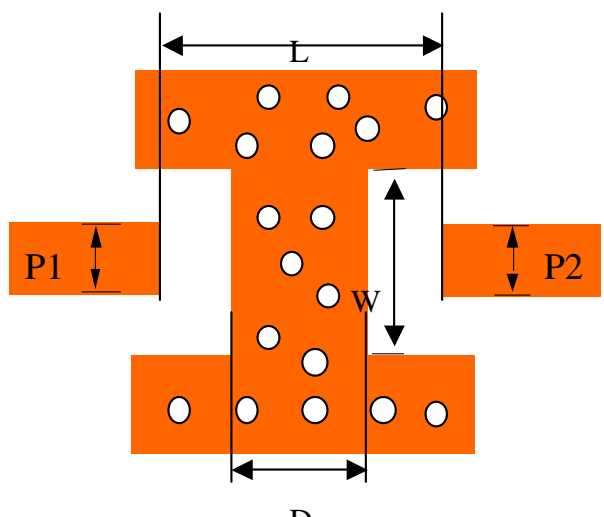
Figure	Dimension		Remark
	L	2.3±0.1 mm	---
	W	1.4±0.1 mm	---
	P1	0.76±0.1 mm	Feed pad
	P2	0.76±0.1 mm	Feed pad
	D	1.5±0.1 mm	Ground pad
	○	d=0.3 mm s=0.8 mm	GBND plane via hole diameter d and edge-to-edge spacing s

11 Note:

1. Please make sure that your product is has been evaluated and confirmed against your specifications when our product is mounted to your product.
2. Do not knock nor drop.
3. All the items and parameters in this product specification have been prescribed on the premise that our product is used for the purpose, under the condition and in the environment agreed upon between you and us. You are requested not to use our product deviating from such agreement.
4. Please keep the distance between transformer/coil and other components (refer to the standard IEC 950)
5. Storage and Handling Requirements
 - (1) Storage period
 - Use the products within 12 months after delivered
 - Solderability should be checked if this period is exceeded
 - (2) Storage conditions
 - *Products should be stored in the warehouse on the following conditions
 - Temperature: -10 ~ 40
 - Humidity : 30% ~ 70% relative humidity no rapid change on temperature and humidity
 - The electrode of the products is coated with solder. Don't keep products in corrosive gases such as sulfur, chlorine gas or acid, or it may cause oxidization of electrode, resulting in poor solderability.
 - *Products should not be stored on bulk packaging condition to prevent the chipping of the core and the breaking of winding wire caused by the collision between the products.
 - *Products should be stored on the palette for the prevention of the influence from humidity, dust and so on.
 - *Products should be stored in the warehouse without heat shock, vibration, direct sunlight and so on
 - (3) Handling Condition
 - Care should be taken when transporting or handing product to avoid excessive vibration or mechanical shock.



Qs 9000 Certificate

CHILISIN ELECTRONICS CORP.

BPF2520T2450HA1 Specification

12 Revision Control :

Revision	Date	Content	Remark
1	2005/2/15	New Issue	
2			
3			