









-  Magnetic Integrated Connector Modules
-  Compliant with IEEE802.3 standard including 350μH OCL with 8mA DC Bias
-  1500Vrms isolation voltage per IEEE802.3
-  Enhanced performance on EMI suppression with metal shield
-  Support various 10/100 transceiver ICs
-  Operating temperature 0°C to +70°C
-  UL 1863 listed
-  RoHS compliant versions are available



GENERAL ELECTRICAL SPECIFICATION @ 25°C

Insertion Loss (dB Max)	Return Loss (dB Min)				CMRR (dB Min)			Crosstalk (dB Min)	Hipot (Vrms)
	1-30MHz	40MHz	50MHz	60-80MHz	32MHz	62MHz	100MHz		
0.1-100MHz	1-30MHz	40MHz	50MHz	60-80MHz	32MHz	62MHz	100MHz	0.1-100MHz	1500
1.0	16.0	14.0	13.0	12.0	42.0	37.0	33.0	35.0	

PART NUMBER TABLE

Part Number ¹	RoHS Part Number	Turn Ratio (Chip : Cable) (±3%)		Configuration ²		LED ³ (Left / Right)	Mechanical Package	Schematic
		Tx	Rx	Tx	Rx			
MJ-11U2NNA4-H34K	MJR11U2NNA4-H34K	1CT:1CT	1CT:1CT	TC	TC	—	MJ11U-02A	H34K ⁴
MJ-11U2NNA4-H34U	MJR11U2NNA4-H34U	1CT:1	1CT:1CT	TCA	CT	—	MJ11U-02A	H34U
MJ-11U2NNA4-K34K ⁷	MJR11U2NNA4-K34K	1CT:1CT	1CT:1CT	TC	TC	—	MJ11U-02A	K34K ⁴

Notes:

1. For different electrical and mechanical specifications, please contact E&E Magnetic Products Limited.
2. Core location are counted from PCB (Chip) side to Cable (Media) side, where:
“T” = Isolation transformer ; “C” = Common-mode choke ; “A” = Auto-transformer
3. LEDs (Left / Right) : “—” = None.
4. Schematic H34K, K34K are suitable for Auto MDI/MDIX applications.
5. Panel tabs are optional.
6. All parts shown in this datasheet have gold plating thickness of 10 micro-inch (min.) over contact area.
Advance options including 30 micro-inch (min.) and 50 micro-inch (min.) are also available.
7. Operating temperature: -40°C to +85°C.



MECHANICAL DIMENSIONS

MJ11U-02A

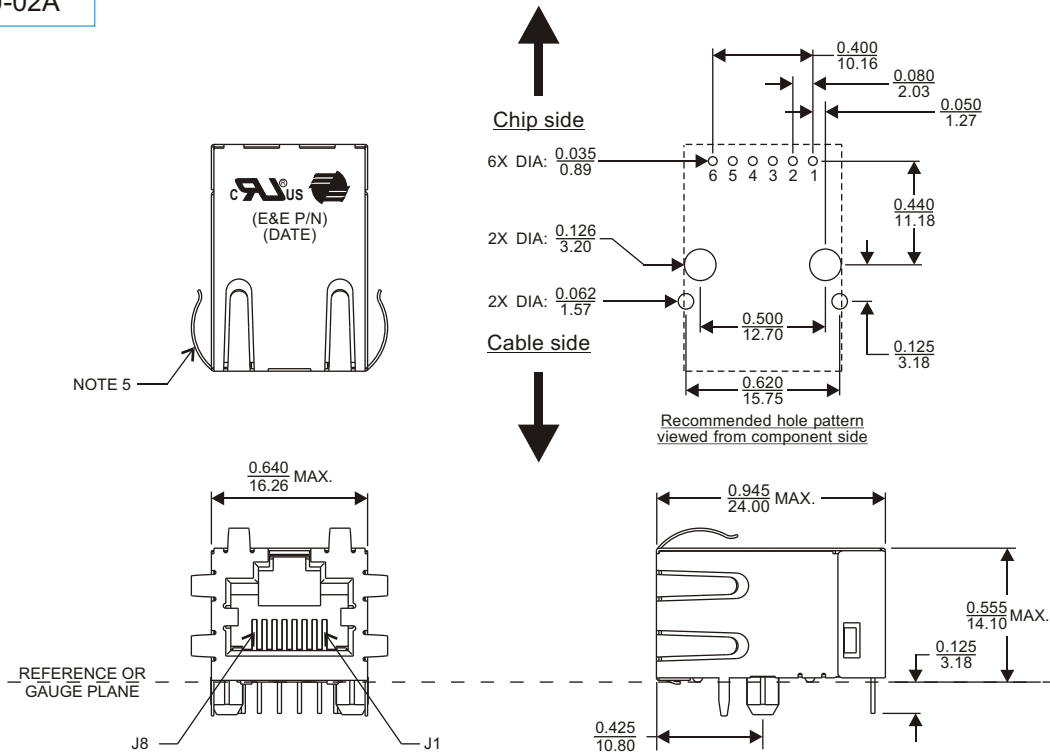

All dimensions are specified in $\frac{\text{inch}}{\text{mm}}$ with higher precedence in inch.

Unless otherwise specified, all tolerances are $\pm \frac{0.010}{0.25}$.

MATERIALS

Housing	Consist of thermoset & thermoplastic materials, all of them are UL 94-V0 rated.
Contact Pins ⁶	Phosphor bronze, plated with nickel under-plating and hard gold over contact area.
PCB Pins	Copper wire which meets solderability requirements per MIL-STD-202, method 208.



SCHMATICS

H34K / K34K

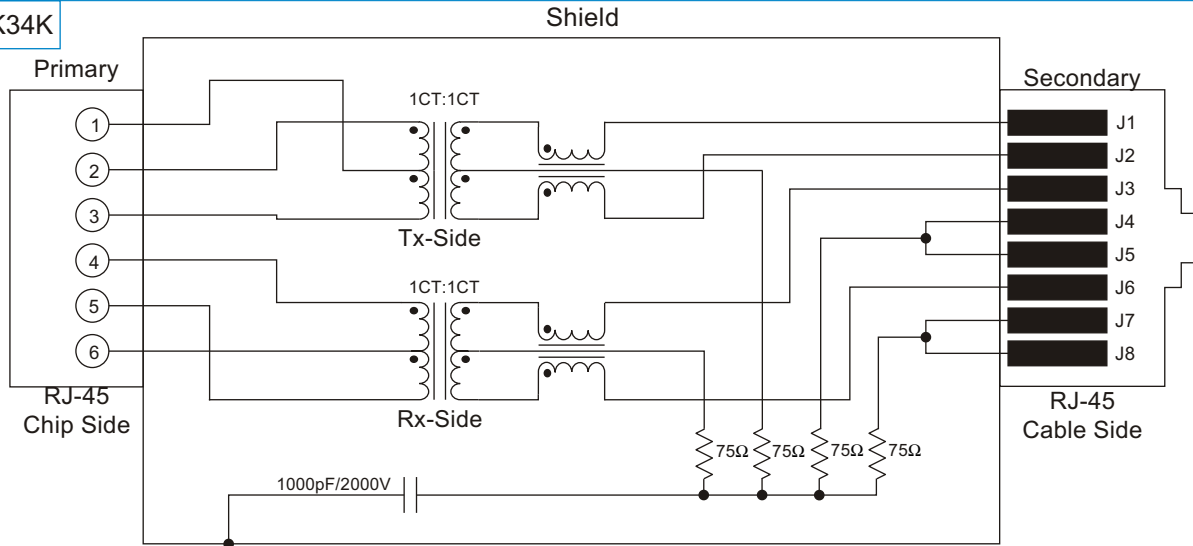

H34U

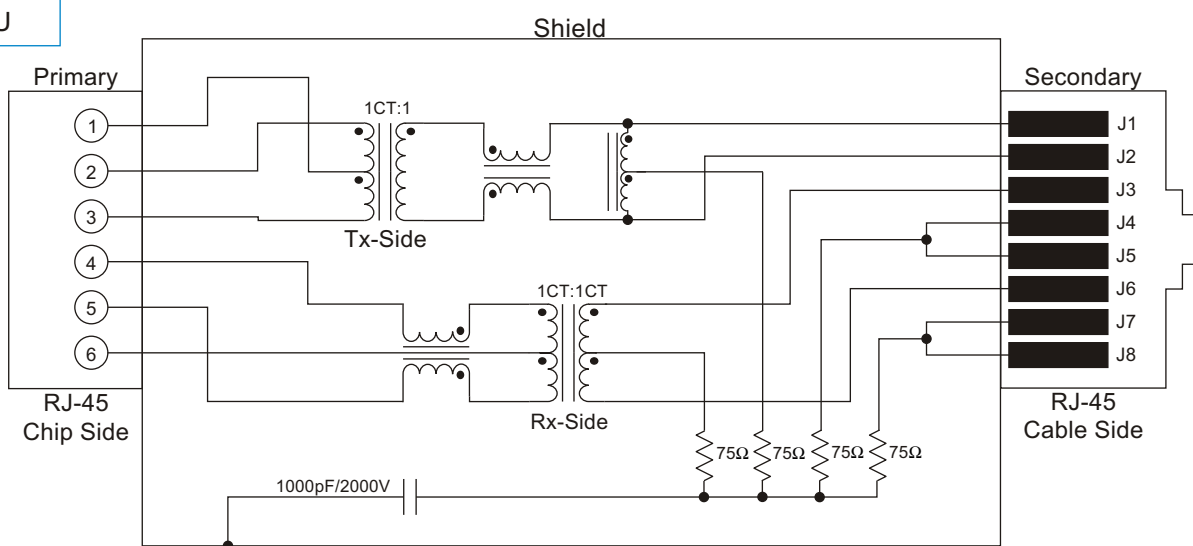

FOR MORE INFORMATION, PLEASE CONTACT

HEADQUARTER
2/F Block A, Merit Industrial Centre,
94 Tokwawan Road, Kowloon,
Hong Kong
Tel: (852) 2765 3888
Fax: (852) 2954 3304
Email: eempl@eleceltek.com
Website: <http://www.eleceltek.com>

Information herein is for reference only and subject to change without notice. It does not constitute any representation, warranty or commitment of the company in respect of the products in any aspect. All logos, brands and product names mentioned herein are trademarks or registered trademarks of their respective owners. The company does not assume any liability arising out of the application or use of any product or circuit described herein. Copyrights 2006, E & E Magnetic Products Limited.