









-  Magnetic Integrated Connector Modules
-  Compliant with IEEE802.3af standard including 350μH OCL with 8mA DC Bias
-  1500Vrms isolation voltage per IEEE802.3af
-  350mA balanced DC line current capability
-  Designed for Power over Ethernet (PoE) enabled Switch / Router / Hub applications
-  Enhanced performance on EMI suppression with metal shield
-  Operating temperature 0°C to +70°C
-  UL 1863 listed
-  RoHS compliant versions are available



GENERAL ELECTRICAL SPECIFICATION @ 25°C

Insertion Loss (dB Max)	Return Loss (dB Min)				CMRR (dB Min)			Crosstalk (dB Min)	Hipot (Vrms)	
	1-30MHz	40MHz	50MHz	60-80MHz	32MHz	62MHz	100MHz			
0.1-100MHz	1.2	16.0	14.0	13.0	12.0	42.0	37.0	33.0	33.0	1500

PART NUMBER TABLE

Part Number ¹	RoHS Part Number	Turn Ratio (Chip : Cable) (±3%)		Configuration ²		LED ³ (Left / Right)	Mechanical Package	Schematic
		Tx	Rx	Tx	Rx			
MJ-11U2NNA8-VB110	MJR11U2NNA8-VB110	1CT:1CT	1CT:1CT	TS	TS	—	MJ11U-09A	VB110
MJ-11U2GYA8-VB110	MJR11U2GYA8-VB110	1CT:1CT	1CT:1CT	TS	TS	G / Y	MJ11U-09B	VB110

Notes:

- For different electrical and mechanical specifications, please contact E&E Magnetic Products Limited.
- Core location are counted from PCB (Chip) side to Cable (Media) side, where:
“T” = Isolation transformer ; “S” = Shared Common-mode choke
- LEDs (Left / Right) : “G” = Green ; “Y” = Yellow ; “—” = None. For different LED color requirements, please contact E&E Magnetic Products Limited.
- Panel tabs are optional.
- All parts shown in this datasheet have gold plating thickness of 10 micro-inch (min.) over contact area.
Advance options including 30 micro-inch (min.) and 50 micro-inch (min.) are also available.

MATERIALS

Housing	Consist of thermoset & thermoplastic materials, all of them are UL 94-V0 rated.
Contact Pins ⁵	Phosphor bronze, plated with nickel under-plating and hard gold over contact area.
PCB Pins	Copper wire which meets solderability requirements per MIL-STD-202, method 208.



MECHANICAL DIMENSIONS

MJ11U-09A

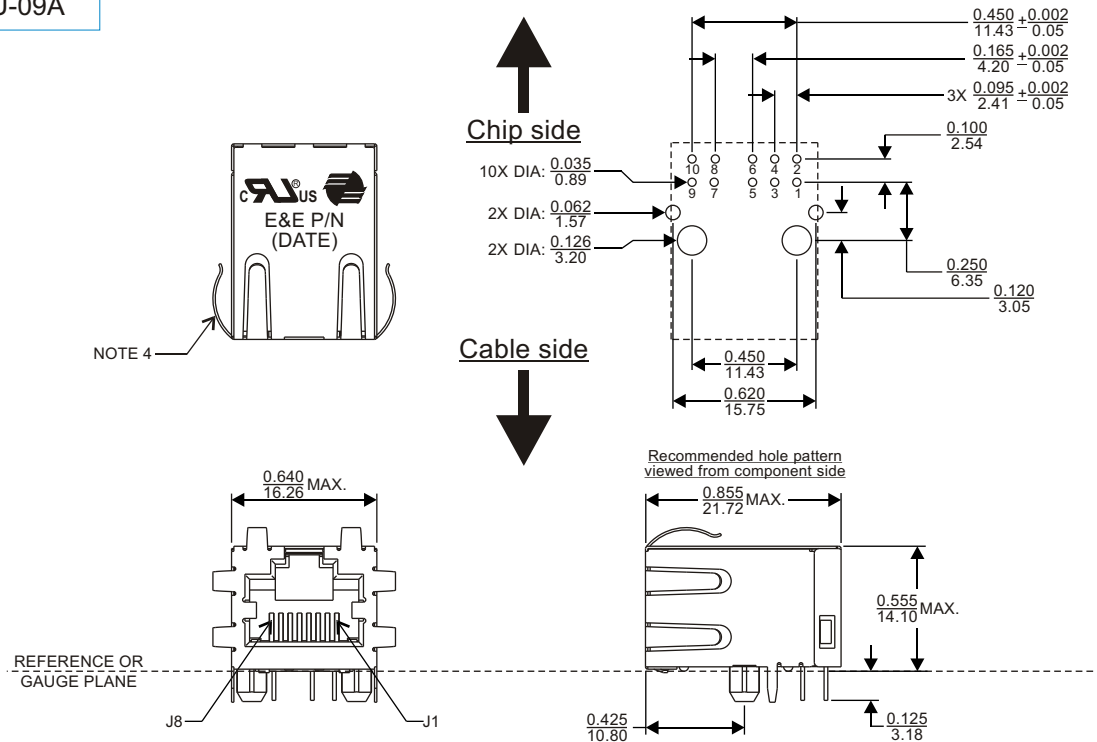

MJ11U-09B

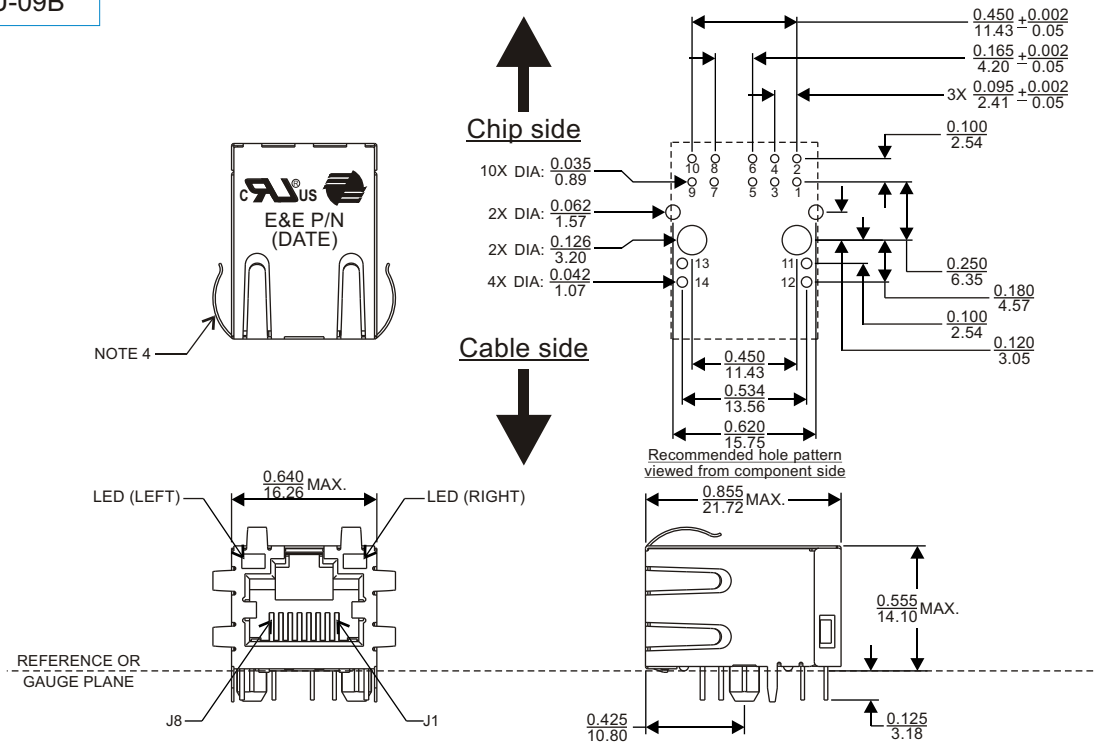

All dimensions are specified in $\frac{\text{inch}}{\text{mm}}$ with higher precedence in inch.

Unless otherwise specified, all tolerances are $\pm \frac{0.010}{0.25}$.



SCHEMATICS

VB110

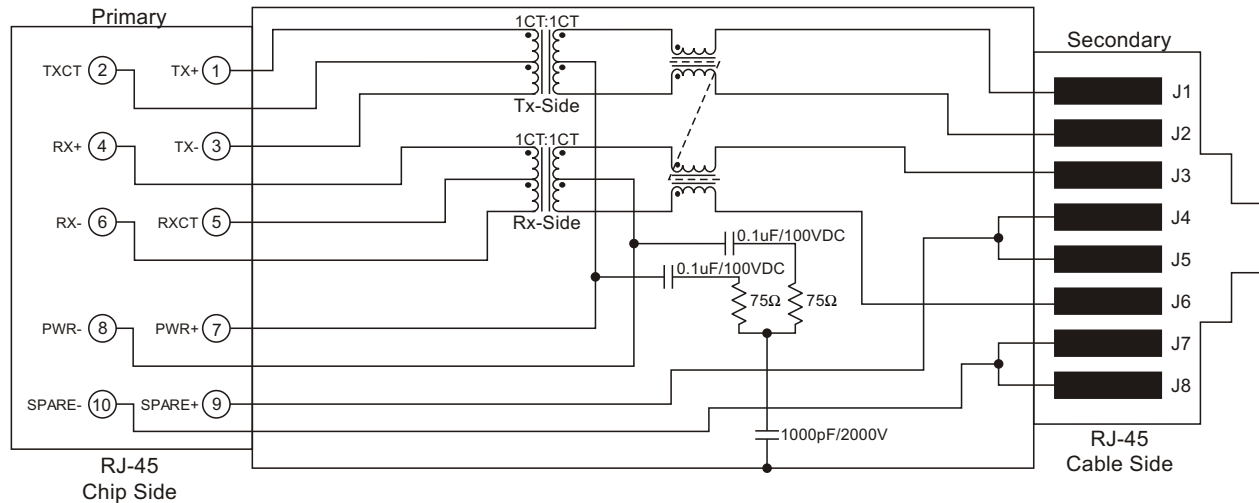

LEDs COLOR AND POLARITY

MJ11U-09B	LED (LEFT)		LED (RIGHT)			
	COLOR	POLARITY		COLOR	POLARITY	
		PIN 13	PIN 14		PIN 11	PIN 12
LED (RIGHT)	GREEN	+	-	YELLOW	+	-
LED (LEFT)						

LED SPECIFICATION @25°C, FORWARD CURRENT = 20mA

Standard Color	Typical Wavelength (nm)	Forward Voltage (volt)	
		Typical	Maximum
Green	565	2.2	2.5
Yellow	590	2.1	2.5

FOR MORE INFORMATION, PLEASE CONTACT

HEADQUARTER
2/F Block A, Merit Industrial Centre,
94 Tokwawan Road, Kowloon,
Hong Kong
Tel: (852) 2765 3888
Fax: (852) 2954 3304
Email: eempl@eleceltek.com
Website: <http://www.eleceltek.com>

Information herein is for reference only and subject to change without notice. It does not constitute any representation, warranty or commitment of the company in respect of the products in any aspect. All logos, brands and product names mentioned herein are trademarks or registered trademarks of their respective owners. The company does not assume any liability arising out of the application or use of any product or circuit described herein. Copyrights 2006, E & E Magnetic Products Limited.