









-  Magnetic Integrated Connector Modules
-  Compliant with IEEE802.3af standard including 350μH OCL with 8mA DC Bias
-  1500Vrms isolation voltage per IEEE802.3af
-  350mA balanced DC line current capability
-  Designed for Power over Ethernet (PoE) enabled Switch / Router / Hub applications
-  Enhanced performance on EMI suppression with metal shield
-  Operating temperature 0°C to +70°C
-  UL 1863 listed
-  RoHS compliant versions are available



GENERAL ELECTRICAL SPECIFICATION @ 25°C

Insertion Loss (dB Max)	Return Loss (dB Min)		Crosstalk (dB Min)	Hipot (Vrms)
	0.1-100MHz	40-100MHz		
1.5	16.0	10.0	30.0	1500

PART NUMBER TABLE

Part Number ²	RoHS Part Number	Turn Ratio (±3%) (Chip : Cable)	Configuration ³	Platform	Mechanical Package	Schematic
MJ-24N2NNA2-E7102	MJR24N2NNA2-E7102	1CT:1	TCA	2x4	MJ24N-07A	E7102
MJ-26N2NNA2-E7102	MJR26N2NNA2-E7102	1CT:1	TCA	2x6	MJ26N-07A	E7102
MJ-28N2NNA2-E7102	MJR28N2NNA2-E7102	1CT:1	TCA	2x8	MJ28N-07A	E7102

Notes:

1. "F" represents the test frequency specified in MHz.
2. For different electrical and mechanical specifications, please contact E&E Magnetic Products Limited.
3. Core location are counted from PCB (Chip) side to Cable (Media) side, where:
"T" = Isolation transformer ; "C" = Common-mode choke ; "A" = Auto-transformer .
4. Panel tabs are optional.
5. All parts shown in this datasheet have gold plating thickness of 10 micro-inch (min.) over contact area.
Advance options including 30 micro-inch (min.) and 50 micro-inch (min.) are also available.



MECHANICAL DIMENSIONS

MJ24N-07A

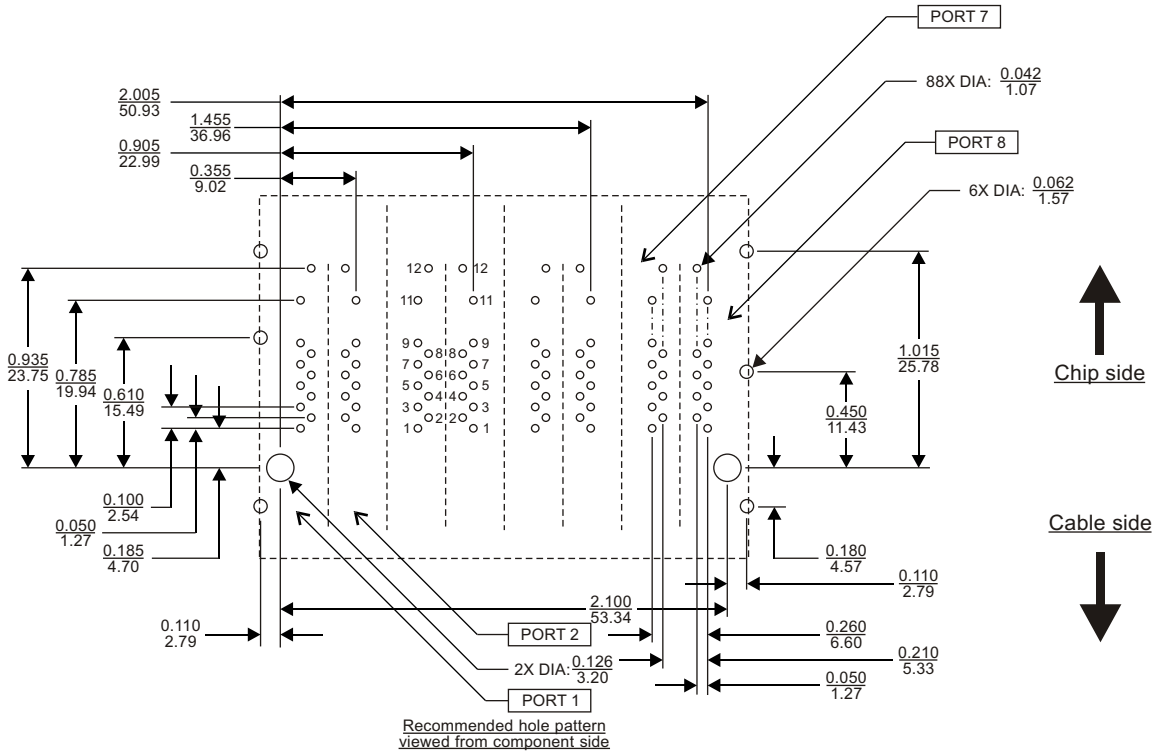
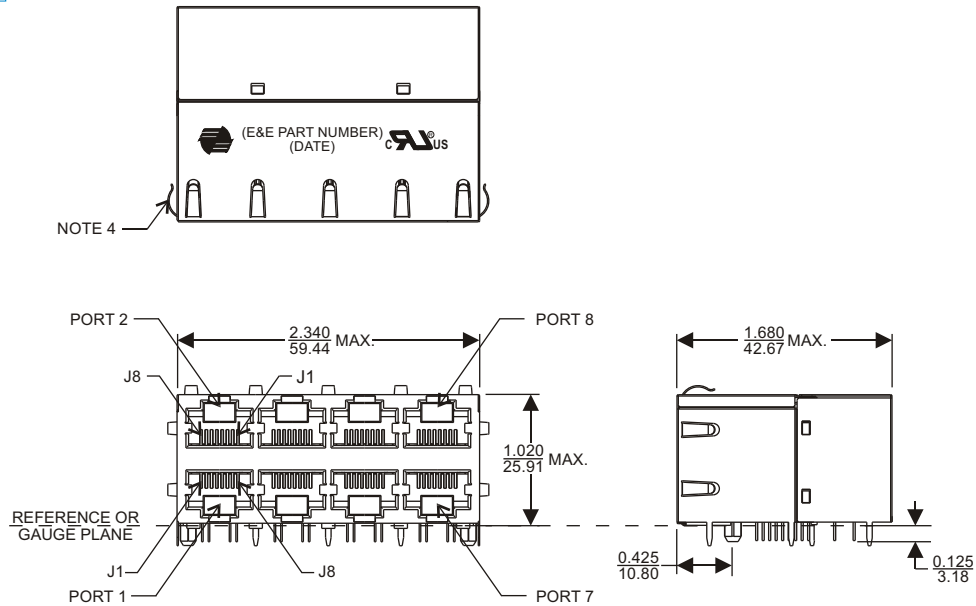

All dimensions are specified in $\frac{\text{inch}}{\text{mm}}$ with higher precedence in inch.

Unless otherwise specified, all tolerances are $\pm \frac{0.010}{0.25}$.



MECHANICAL DIMENSIONS

MJ26N-07A

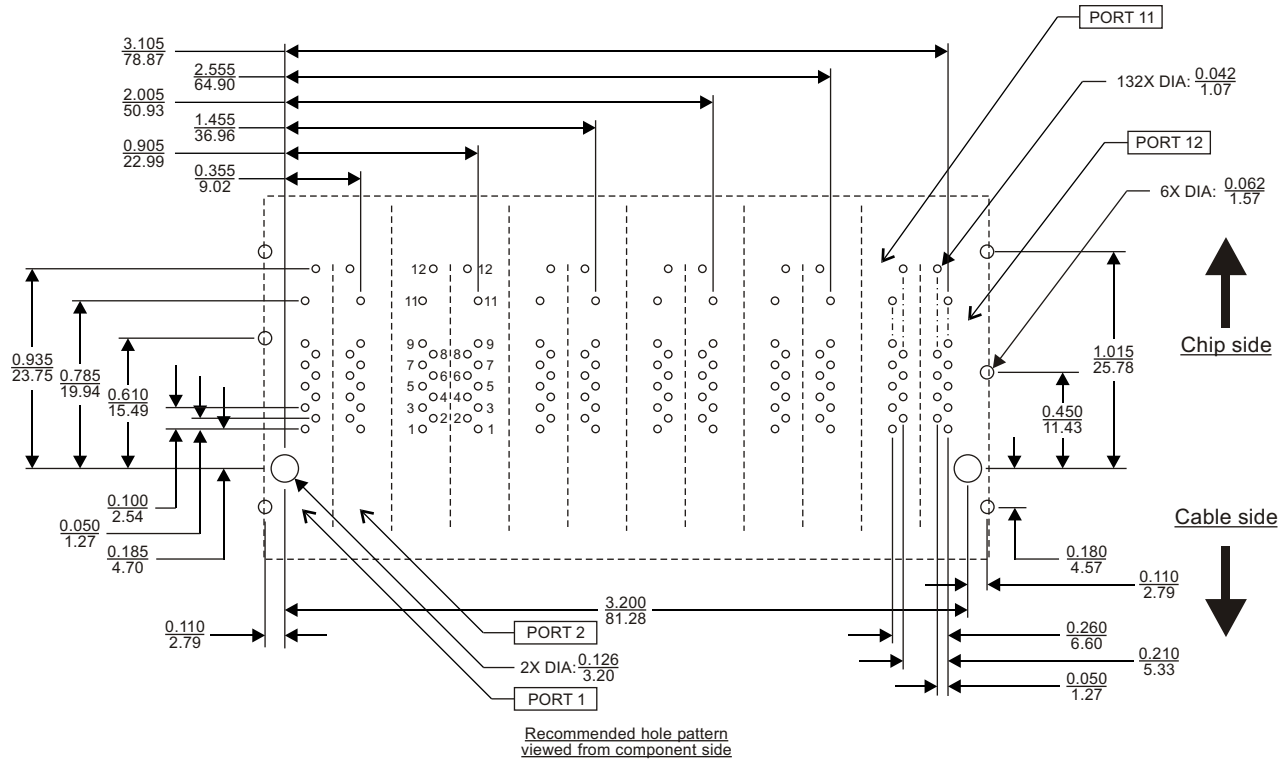
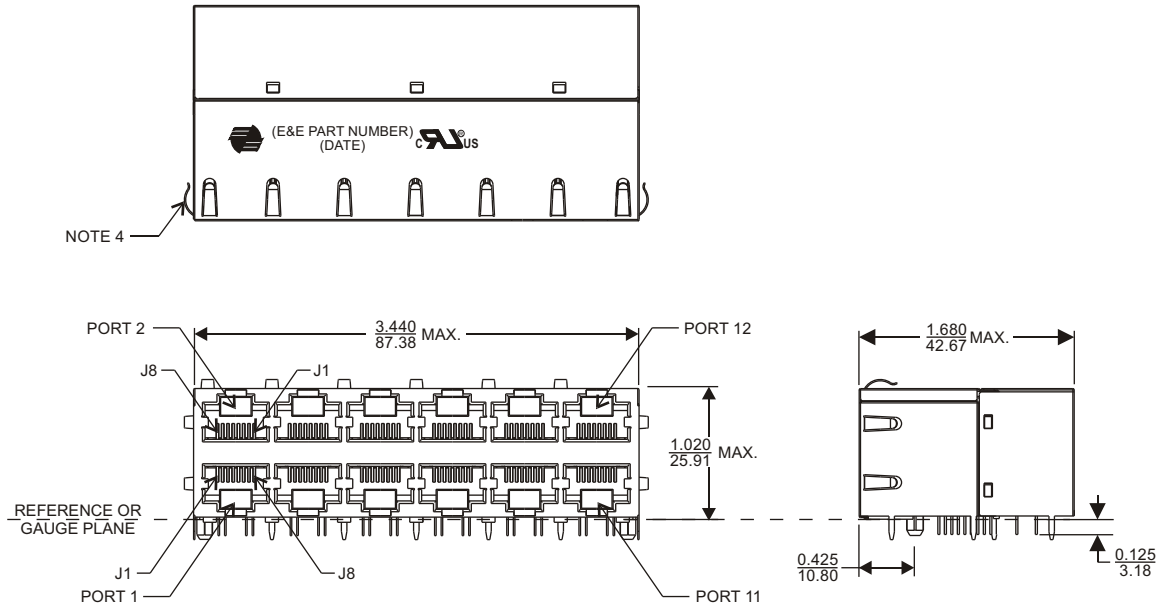

All dimensions are specified in $\frac{\text{inch}}{\text{mm}}$ with higher precedence in inch.

Unless otherwise specified, all tolerances are $\pm \frac{0.010}{0.25}$.



MECHANICAL DIMENSIONS

MJ28N-07A

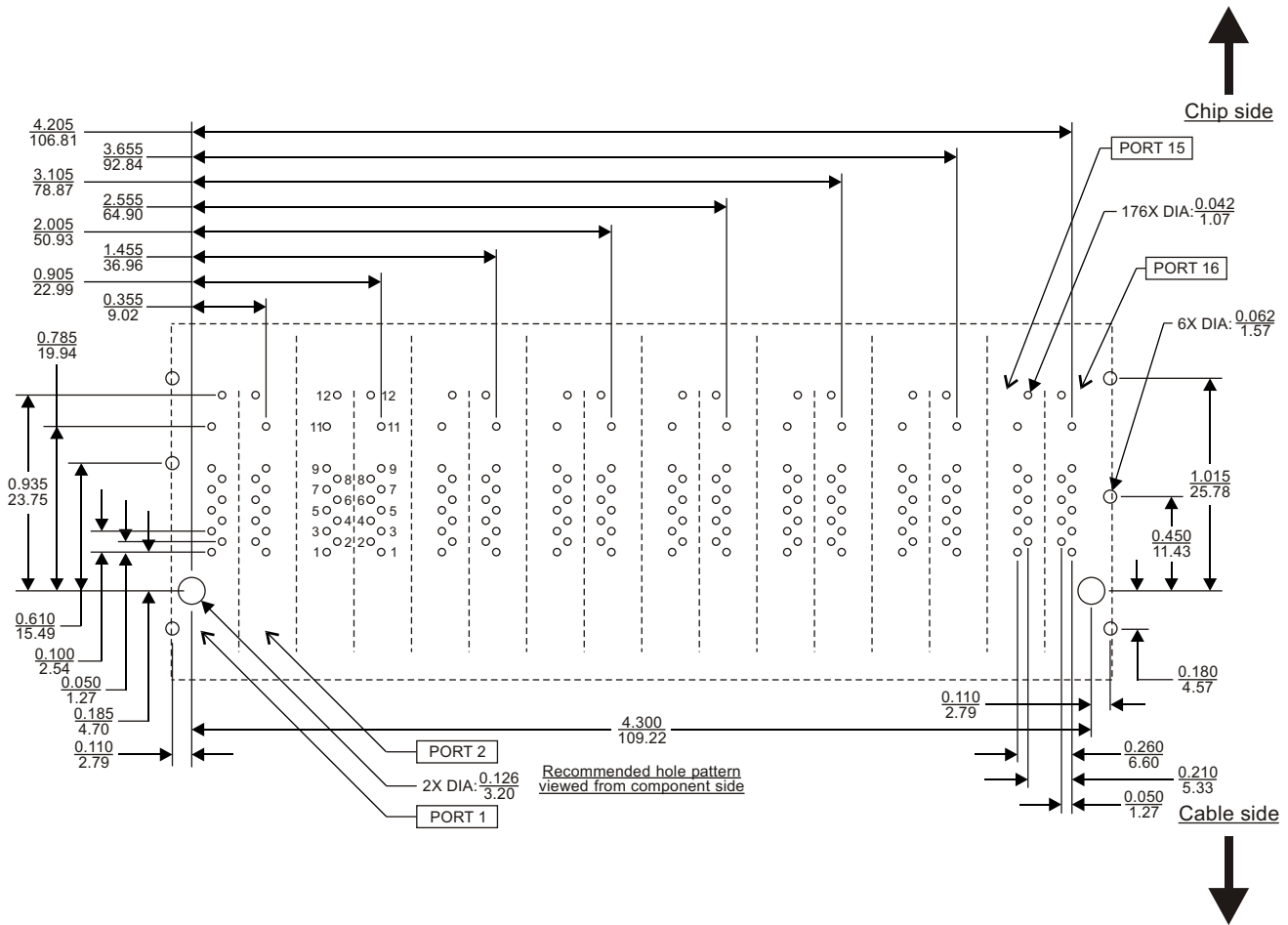
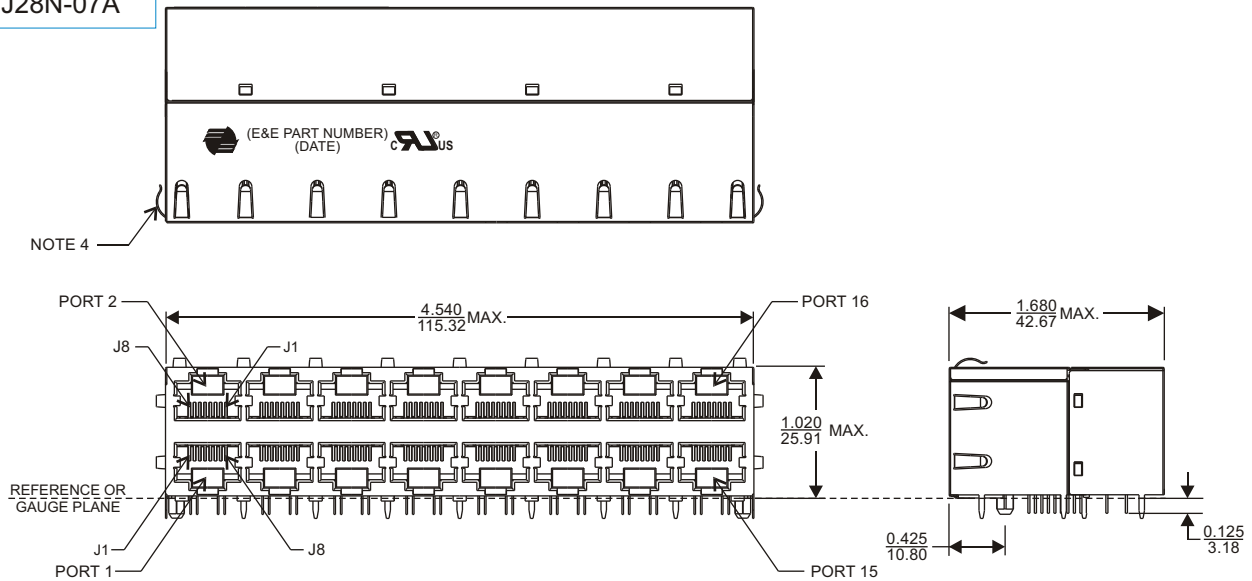

All dimensions are specified in $\frac{\text{inch}}{\text{mm}}$ with higher precedence in inch.

Unless otherwise specified, all tolerances are $\pm \frac{0.010}{0.25}$.

SCHEMATICS(EACH PAIR PORT)

E7102

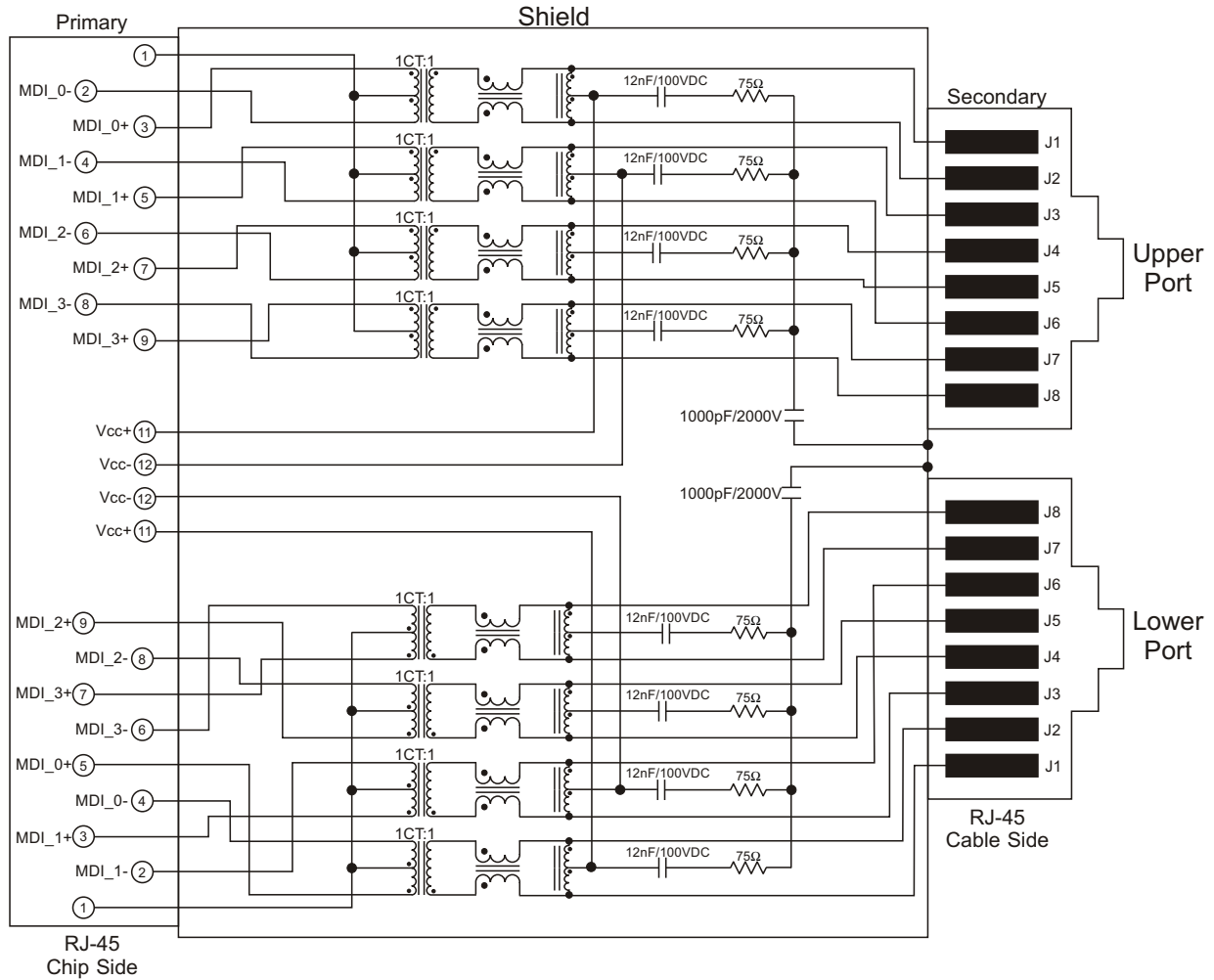

MATERIALS

Housing	Consist of thermoset & thermoplastic materials, all of them are UL 94-V0 rated.
Contact Pins ⁵	Phosphor bronze, plated with nickel under-plating and hard gold over contact area.
PCB Pins	Copper wire which meets solderability requirements per MIL-STD-202, method 208.

FOR MORE INFORMATION, PLEASE CONTACT

HEADQUARTER
2/F Block A, Merit Industrial Centre,
94 Tokwan Road, Kowloon,
Hong Kong
Tel: (852) 2765 3888
Fax: (852) 2954 3304
Email: eempl@eleceltek.com
Website: <http://www.eleceltek.com>

Information herein is for reference only and subject to change without notice. It does not constitute any representation, warranty or commitment of the company in respect of the products in any aspect. All logos, brands and product names mentioned herein are trademarks or registered trademarks of their respective owners. The company does not assume any liability arising out of the application or use of any product or circuit described herein. Copyrights 2006, E & E Magnetic Products Limited.