

CONDUCTIVE POLYMER HYBRID ALUMINUM ELECTROLYTIC CAPACITORS

YT Chip type, Ultra High Temperature Series



- High temperature range, for 150°C use
- Complied to the RoHS directive

Item	Characteristics										
Operating temperature range	-55 ~ +150°C										
Leakage current max.	$I = 0.01CV$ or $3\mu A$ whichever is greater (after 2 minutes)										
Capacitance tolerance	$\pm 20\%$ at 120Hz, 20°C										
Dissipation factor max. (at 120Hz, 20°C)	<table border="1"> <tr> <td>WV</td> <td>25</td> <td>35</td> <td>50</td> <td>63</td> </tr> <tr> <td>tanδ</td> <td>0.14</td> <td>0.12</td> <td>0.1</td> <td>0.08</td> </tr> </table>	WV	25	35	50	63	tan δ	0.14	0.12	0.1	0.08
	WV	25	35	50	63						
tan δ	0.14	0.12	0.1	0.08							
Low temperature characteristics (Impedance ratio at 100kHz)	$Z(-25^\circ C) / Z(+20^\circ C) \leq 1.5$ $Z(-55^\circ C) / Z(+20^\circ C) \leq 2.0$										
Load life	After an application of DC bias voltage plus the rated AC ripple current for 1000 hours at 150°C. The measurement shall meet the following limits. The DC voltage plus the peak AC voltage combined must not exceed the rated voltage.										
	Capacitance change	Within $\pm 30\%$ of initial value									
	tan δ	Less than 200% of the specified value									
	ESR	Less than 200% of the specified value									
	Leakage current	Less than specified value									
Shelf life (at 150°C)	After 1000 hours no load test, leakage current, capacitance and tan δ are same as load life value. The measurement shall be performed at 20°C by the KS C IEC 60384 - 4										
Resistance to soldering heat	The following specifications shall be satisfied when the capacitors are restored to 20°C after exposing them at 250°C for 10 seconds.										
	Leakage current	Less than specified value									
	Capacitance change	Within $\pm 10\%$ of initial value									
	tan δ	Less than specified value									

DRAWING

Unit : mm

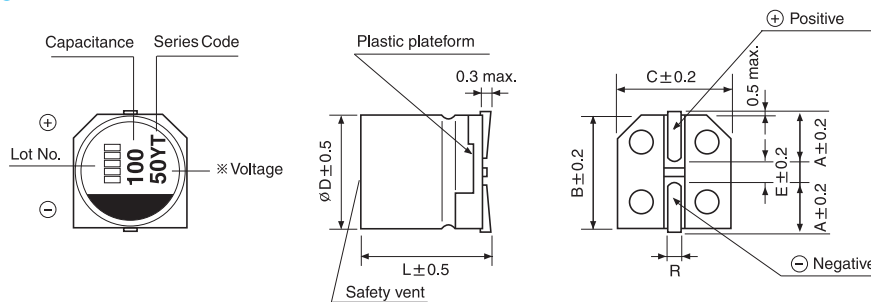

$\phi D \times L$	A	B	C	E	R
6.3×7.7	2.4	6.6	6.6	2.2	0.5~0.8
8×10	2.9	8.3	8.3	3.1	0.8~1.1
10×10	3.2	10.3	10.3	4.5	0.8~1.1

DIMENSIONS & MAXIMUM PERMISSIBLE RIPPLE CURRENT

μF	WV	25		35			50			63		
15												
22							6.3×7.7	80	410	6.3×7.7	80	410
33										8×10	40	610
47				6.3×7.7	60	510						
56							8×10	35	660	10×10	30	710
68	6.3×7.7	45	540									
100				8×10	30	710	10×10	28	780			
150	8×10	27	740	10×10	23	830						
270	10×10	22	850									

Ripple current (mA rms) at 150°C, 100kHz
 ESR (Ω) at 20°C, 100kHz
 Case size $\phi D \times L$ (mm)

FREQUENCY COEFFICIENT OF PERMISSIBLE RIPPLE CURRENT

Frequency	120Hz	1kHz	10kHz	100kHz
Coefficient	0.05	0.30	0.70	1.00