

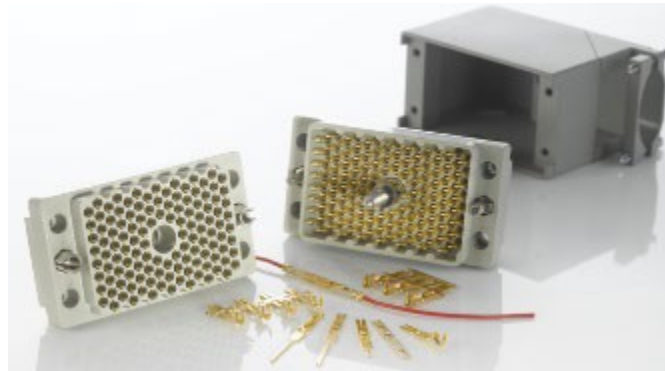

EDAC Gruppe Steckverbinder & Verbindungs Lösungen



EDAC Vorstellung 2019
Blume Elektronik Distribution GmbH



Die EDAC GROUP: Wer sind wir?

Hier die Zusammenfassung:

Die EDAC Gruppe sind führend in der Entwicklung und Herstellung von Steckverbinder Lösungen.

EDAC hat weit über 7000 Kunden die direkt und über den globalen Großhandel & Distribution erfolgreich beliefert werden.

Die Gruppe besteht aus drei Firmen, **EDAC** (www.edac.net), **Norcomp** (www.norcomp.net), und **MH Connectors** (www.mhconnectors.co.uk).

Die Firma wurde in 1965 gegründet, der Hauptsitz ist in Markham, Ontario Canada und hat Filialien in Europe, USA, Canada und Asien.

EDAC GROUP: WHO ARE WE?

- Global Connector Manufacturer
- Over 50 years of providing leading edge interconnect solutions globally
- Extensive breadth of interconnect products
- Customization capability – Low MOQ, fast turnaround, flexible tooling options
- Competitively priced, lower MOQ and shorter lead times
- Global operations, fully integrated manufacturing facilities
- Low cost manufacturing supported by North American Operational Center
- We manufacture products for other companies
- Currently serving the following industries:
 - ❖ Group individual intro
 - ❖ EDAC intro
 - ❖ Product overview
 - ❖ Current customers
 - ❖ Resources

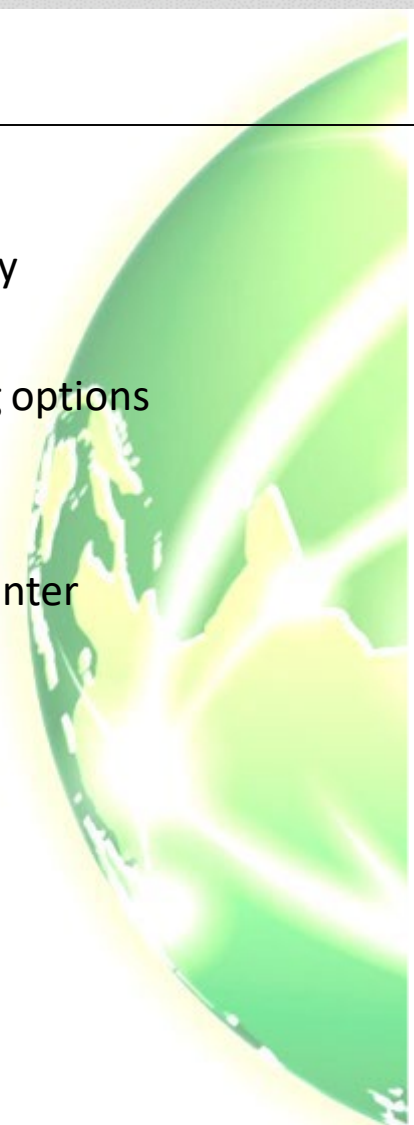

EDAC GROUP: WHERE WE ARE

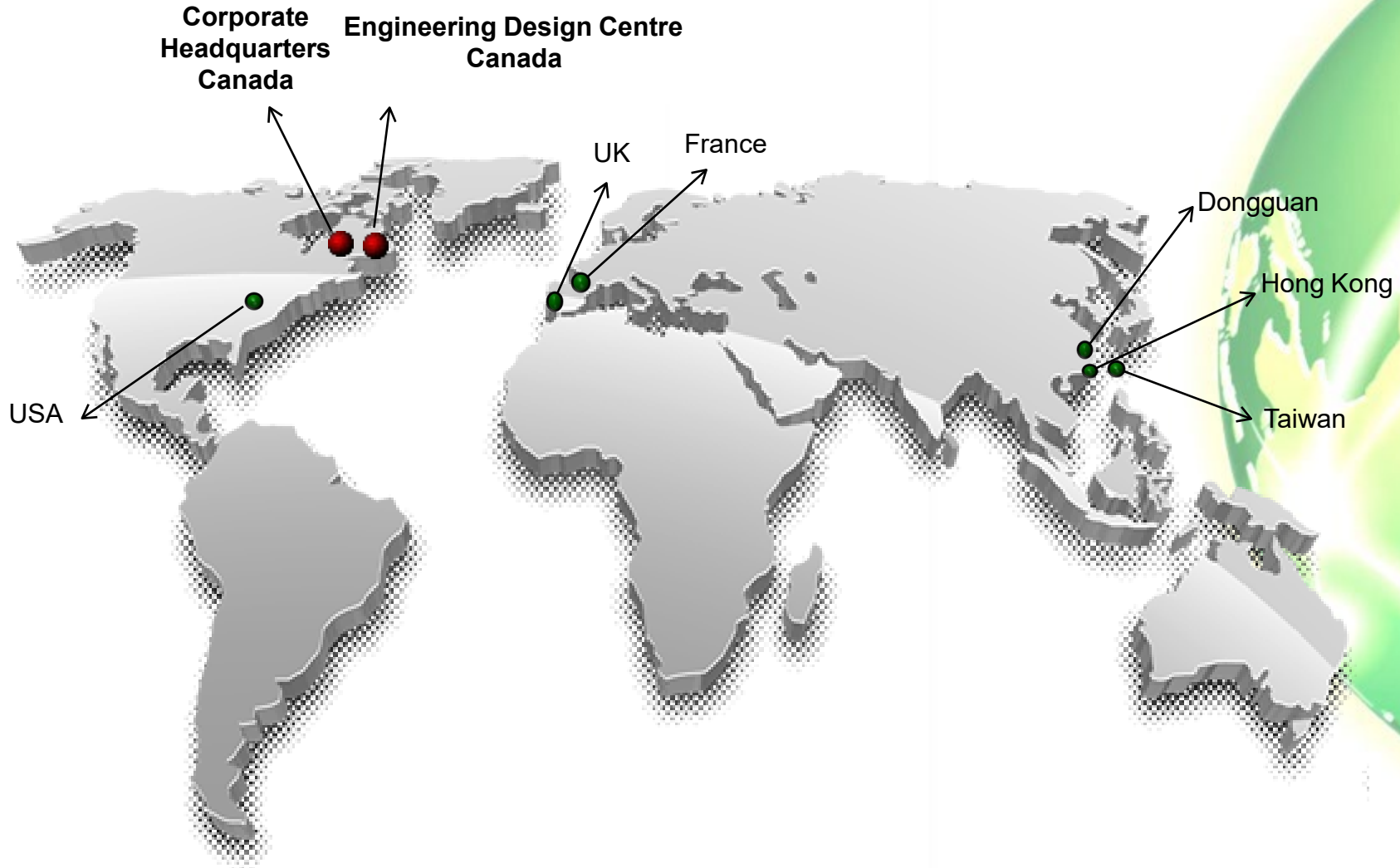

EDAC GROUP: WHERE WE ARE

EDAC Inc.

161 Alden Road,
Units 7 & 8,
Markham, Ontario,
L3R 3W7
Canada
Tel: (416) 754-3322
Fax: (416) 754-3299

NORCOMP

3810 Shutterfly Rd. Suite
#200 Charlotte, N.C. 28217
Tel : +1-704-424 5448
Fax : +1-704-424 5648

EDAC Europe.

12 Fleming Close,
Park Farm North,
Wellingborough,
NN8 6UF,
United Kingdom
Tel: + 44 1933 427300
Fax: + 44 1933 677611

EDAC (Taiwan) Ltd.

12F. , No.27-3, Sec.2
Jhongjheng E. Rd
Danshuei Township
Taipei
Tel: +886-2-8809 1480
Fax : +886-2-8809 1460

EDAC (Dongguan) Ltd.

Chang An Wu Sha
International Park
Chang An Town,
Dongguan,
Guangdong Province
China
Tel: +86-769-3893
2188 /8547 8068
Fax: +86-769-3893
2273 /8584 6868

EDAC GROUP

- 50 years of dedicated interconnect solutions
- Privately held, unencumbered
- Global Operations, fully integrated manufacturing facilities
- Global network of representatives and distributors
- Dedicated to continued investment in new products, both industry standard and custom product
- Focused on solutions rather than just products
- Dedicated, flexible team focused on top quality Interconnect solutions that enhance customer applications and exceed all expectations

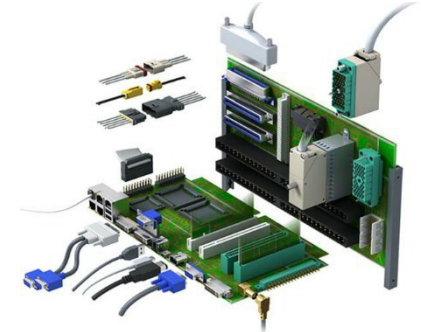

EDAC GROUP: OUR VALUE

- Account Team dedicated to our customers
- Manufacturing and Engineering Technology
- OEM and Distribution Channels
- Customized Products
- Standard Products
- RoHS Compliant, UL Recognized & ISO Certified

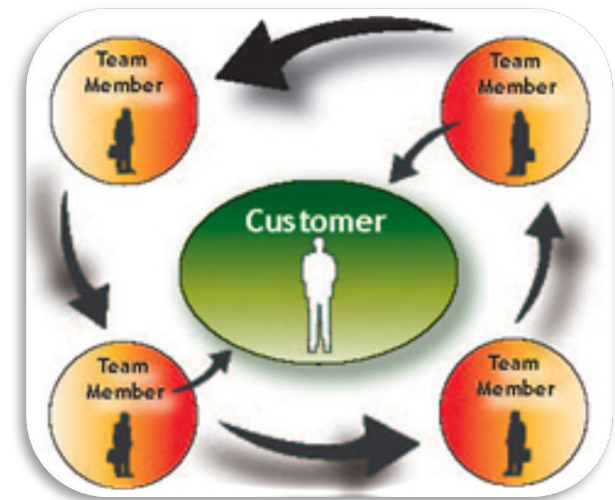

Business
Requirements

Design & Development

Manufacturing

Service

EDAC GROUP: INDUSTRIES / MARKET TYPES SERVED

CIRCULAR - IP68 PERFORMANCE



PRECISION SENSORS



TELECOMMUNICATIONS



INDUSTRIAL CONTROLS



DATA STORAGE



LED LIGHTING



WIND TURBINES



MEDICAL



TEST & MEASUREMENT



SECURITY & ALARMS



CERN - LHC



HARSH ENVIRONMENTS



EDAC GROUP: SALES CHANNEL

We are a service driven company, achieved through OEM & Distribution Channels

- OEM / CM DIRECT



SIEMENS

Rockwell
Collins



SONY

Schneider
Electric

Honeywell
Aerospace



GARMIN

Google

POLYCOM

Vestas

JABIL

Celestica

SANMINA

FLEXTRONICS
GLOBAL SERVICES

FOXCONN

- DISTRIBUTION



EDAC GROUP: SALES CHANNEL

We are a service driven company, achieved through OEM Channels

- OEM / CM DIRECT



SIEMENS

Rockwell
Collins



SONY

Schneider
Electric

Honeywell
Aerospace



GARMIN

Google

POLYCOM

Vestas

JABIL

Celestica

SANMINA

FLEXTRONICS
GLOBAL SERVICES

FOXCONN

EDAC CONNECTORS : STANDARD RANGE

- Card Edge / Press-Fit
- Rack and Panel
- PCB Mounting D-Sub: Standard & High Density, IDC, Stamped / Machined Contacts
- RJ45 Modular & Magnetic Jacks & Plugs
- Waterproof Inline
- USB 2.0/3.0, Type C 3.1,
- B57 "Centronics" Style
- High Rel Interlock
- DIN41612
- Pin Headers
- PLCC Sockets

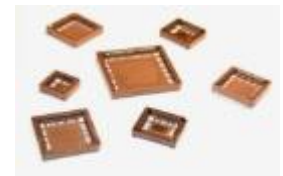

All products can be modified to a customer specification, i.e. options for terminations, colors, plating, number of positions. Drawings and models are available at www.edac.net

EDAC CONNECTORS

- Custom Connectors is the heart of what we do. We can build the exact connector you need, instead of you accepting one that might fit.
- To compliment this, we also offer a very wide range of standard connectors such as Card Edge, Rack & Panel, RJ45, USB, B57, PLCC, Waterproof, which can all be modified with low MOQ's
- Engineering team based in Toronto, Canada.
- Blend of global, national, regional and local distribution and sales networks
- World class, high quality products
- Our MOQ's are lower, and our ROI expectations are lower. It's not our policy to discontinue products, peace of mind
- Superior web presence with 3D CAD drawings and the ability to "Buy It Now" using our distributors latest inventory information
- Strong customer service support teams in Toronto, Canada
- EDAC group – focusing only on connector technologies and solutions

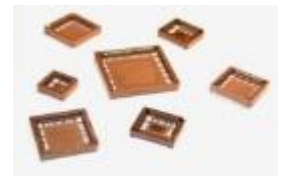
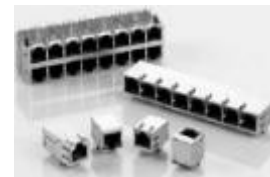

MH CONNECTORS

- MH Connectors was formed in 1985 In Corby UK
- Leading manufacturer of hoods / back shells in particular for D-Subs and RJ45
- Recognized name for high quality cable mounted / waterproof D-Sub connectors Waterproof circular connectors
- MH Connectors was acquired by EDAC in 2010
- Blend of global, national, regional and local distribution and sales networks
- World class, high quality products
- Our MOQ's are lower, and our ROI expectations are lower. It's not our policy to discontinue products, peace of mind



MH CONNECTORS: D-SUB

Extensive Offering of D-Sub Hoods

- Plastic, Metal and Metalized
- Available for 9 to 50 way connectors and high density 15 to 78 way connectors
- EMI/RFI Shielded
- Single, dual or triple cable entry options
- Multiply hardware and strain relief options
- Full custom capability

D-Sub Connectors

- Cable Mount and Board Mount
- Stamped and Formed Contacts
- High Quality Machined Contacts
- Solder, Crimp or IDC available
- Vertical or right angle
- Mixed layout connectors with the option of 10, 20 or 40Amp contacts
- Coaxial 50Ω and 75Ω available



EDAC: DISTRIBUTION



- We are a distribution oriented company
- Significant portion of sales are realized through distribution
- Our comprehensive interconnect offering is available through distribution
- Distribution sales channels are important for growth
- Global distributors to help increase our reach and strengthen our brand image
- Distributors can register designs for any EDAC product
- All projects are closely monitored by our Regional BDM's
- Our Regional BDM's receive recognition for the distributors POS

EDAC GROUP



Applications



EDAC...Connecting Your World!



EDAC GROUP: CONNECTORS - STANDARD RANGE

- Card Edge / Press-Fit
- Rack and Panel
- D-Sub: Standard & High Density, IDC, Stamped / Machined Contacts
- RJ45 Modular & Magnetic Jacks & Plugs
- Waterproof Inline
- Waterproof circular
- Waterproof D-Subs

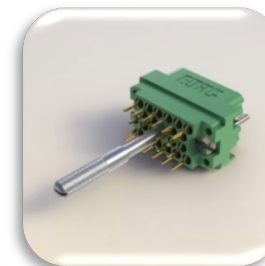
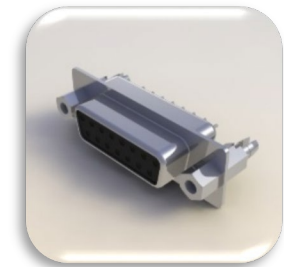

EDAC GROUP: CONNECTORS - STANDARD RANGE

- Hoods & Backshells
- USB 2.0/3.0/Type C, DVI
- B57 “Centronics” Style
- High Rel Interlock
- DIN41612
- Pin Headers
- PLCC Sockets
- Cable assemblies

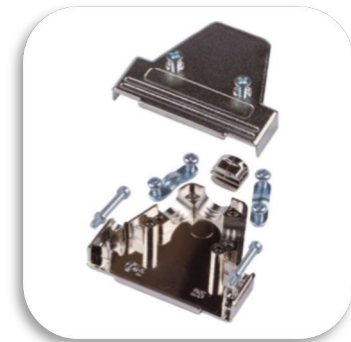

EDAC GROUP: CONNECTORS –Automotive Market

- Custom d-sub cable assemblies in automotive Diagnostic equipment applications.
- OBD2 (On Board Diagnostic) Connectors in Tier 1 and aftermarket applications.
- IP67 waterproof plug and socket connectors.
- USB connectors Type A and Type C for cabin applications.
- Circular connectors alternative to Deutsch style connectors.
- Custom wire harness with multiple connectors, wafer, ribbon, terminals and power connectors.
- RJ45 connectors in next generation smart vehicles for diagnostics, infotainment, and systems applications.
- Automotive certifications are evaluated on an application basis.



EDAC GROUP: APPLICATIONS, TRANSPORTATION & INFRASTRUCTURE



For use in next generation In Flight Entertainment, Rail & Bus travel

D-Subs

USB



EDAC GROUP: APPLICATIONS, COMMUNICATIONS

MAGNETIC AND NON-MAGNETIC JACKS

- Single or Multiport up to 2X8
- Shielded or unshielded tab up or down
- With or without LED's
- We can match most common PHY circuits
- POE versions available

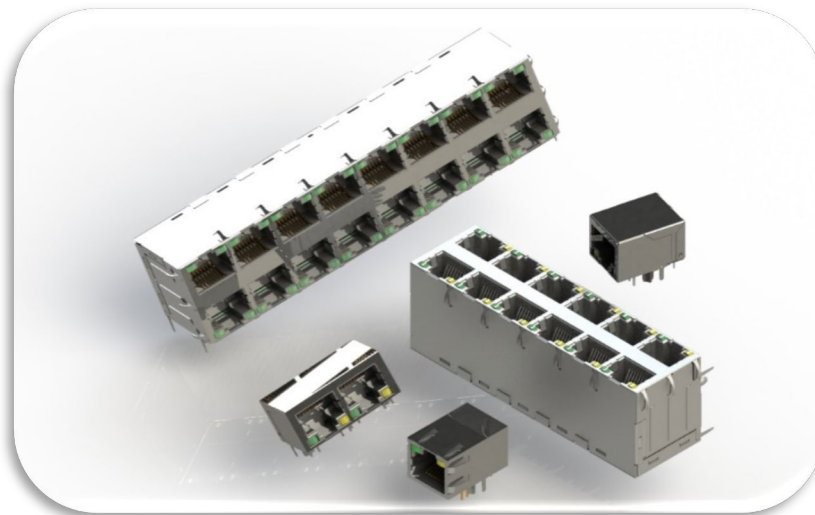

EDAC GROUP

560 Series Wire to Wire & Wire to PCB

Wire to Wire

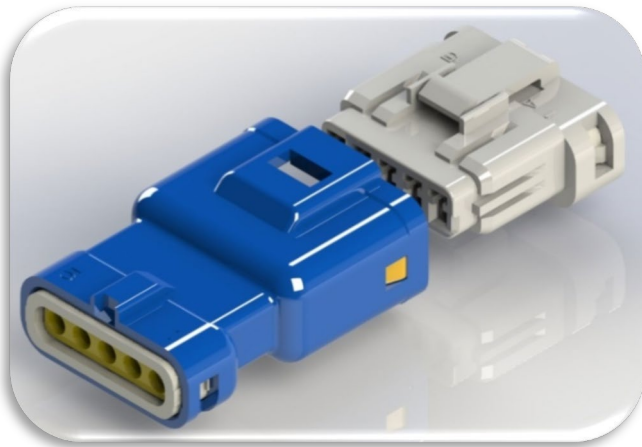

Features

- IP67 Certified
- Double Latch
- 2.5mm Pitch
- Rated Current: 3A max, 250V
- Seals are preassembled into housing
- Internal Polarization
- Crimp and Poke Contacts
- Waterproofing Cap seals unused contact positions
- Available as pre assembled cable assemblies

Wire to PCB - Headers

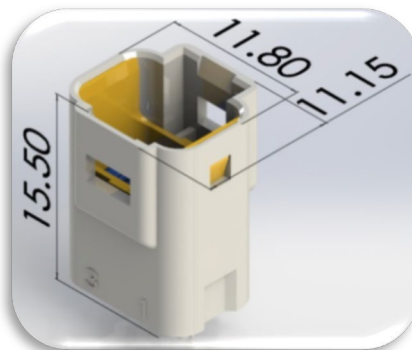
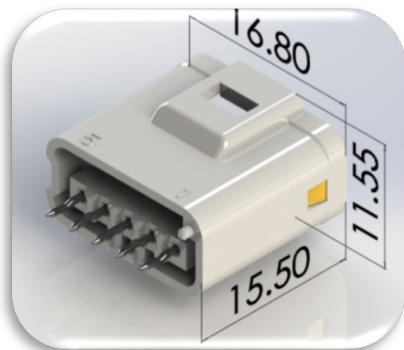

EDAC GROUP

572 Series Wire to Wire & Wire to PCB

Wire to Wire

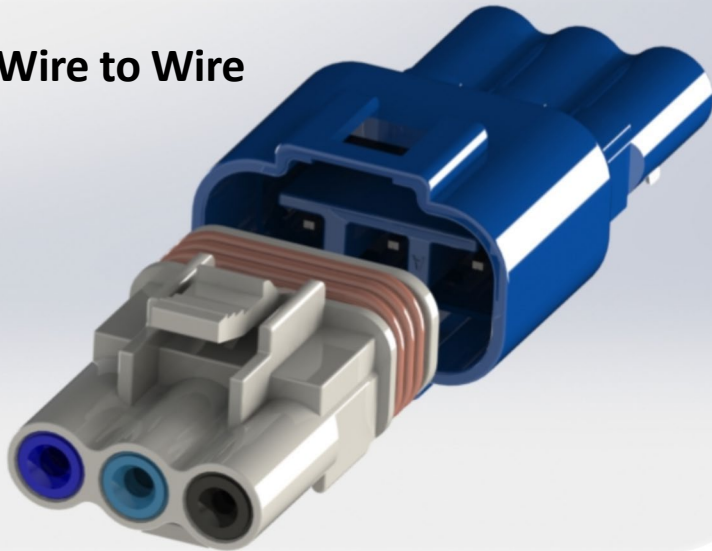

Wire to PCB - Headers

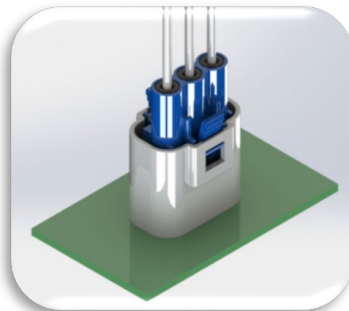
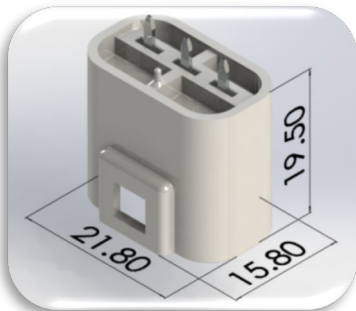

Features

- IP67 Certified
- Double Latch
- 5.8mm Pitch
- Rated Current: 10A max, 300V
- Seals are assembled onto each individual wire
- Internal Polarization
- Crimp and Poke Contacts
- Available as pre assembled cable assemblies

EDAC GROUP

560 Applications - Automatic Faucets



EDAC GROUP

560 Applications - Automatic Faucets

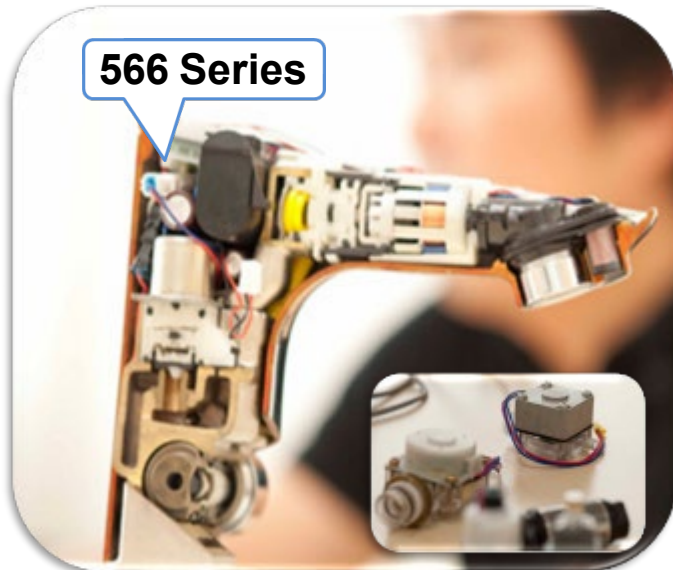

**Flow sensor is activated using stored electricity from the water flow.
No need for a power supply.**

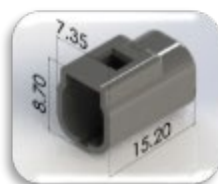
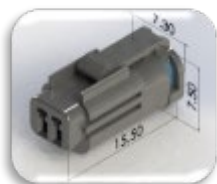

Controller will use stored electricity (Control of Sensor & Solenoid Valve open & close)

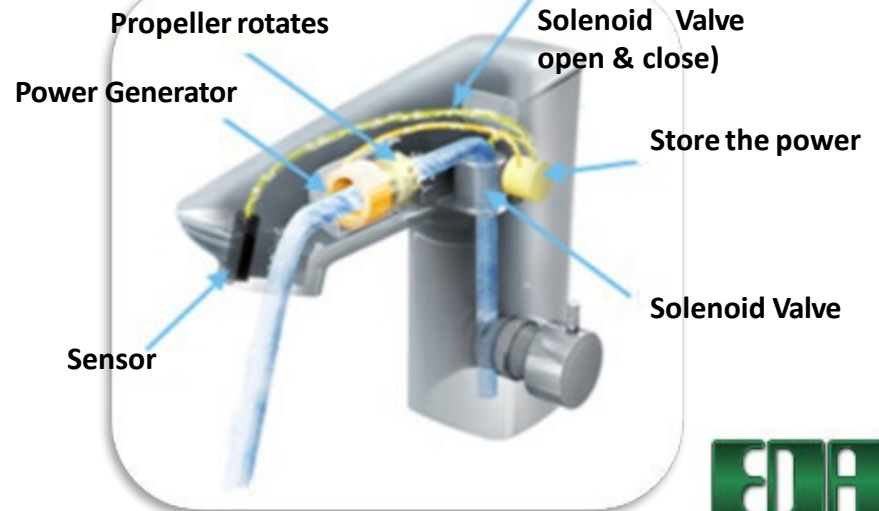

EDAC GROUP

572 Applications - Street Lighting

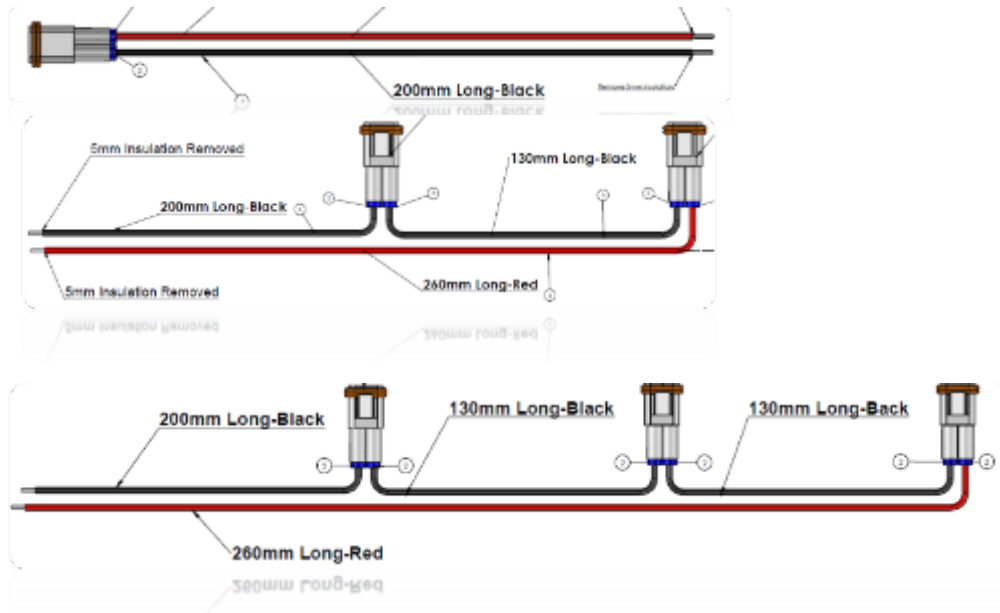

1 or 2 or 3 banks of LED's used depending on height of Light



EDAC GROUP

Applications Power Grid & Generation

Next Generation Grid Control & Monitoring.

- Single port 1000 base & 100 Base Magnetic jack,
- RJ45 Mod Jacks,
- mini SMT USB
- DIN41612
- D Sub
- Edge card

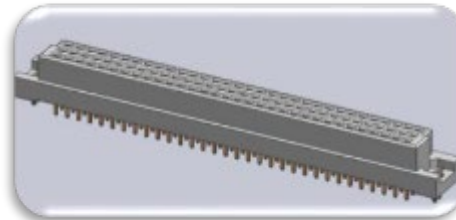

EDAC GROUP

516 Applications Trackside Equipment

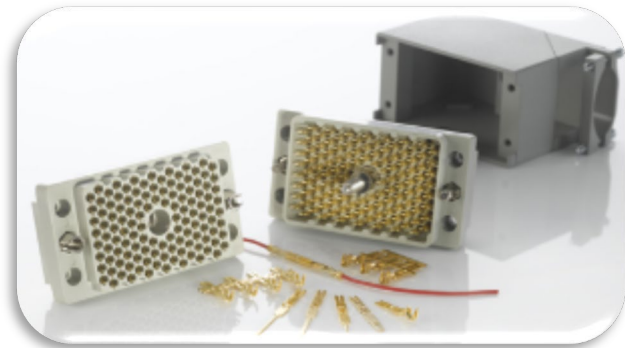

Network Rail



HIGH RELIABILITY
RANGE
Rack & Panel
Connectors



EDAC GROUP

516 Applications – Audio Mixers

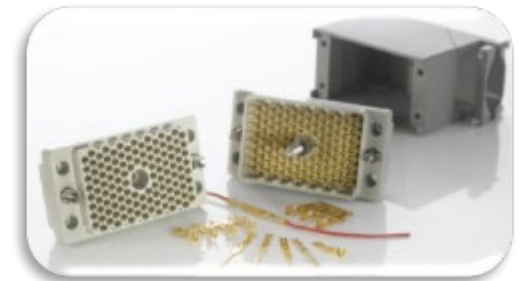
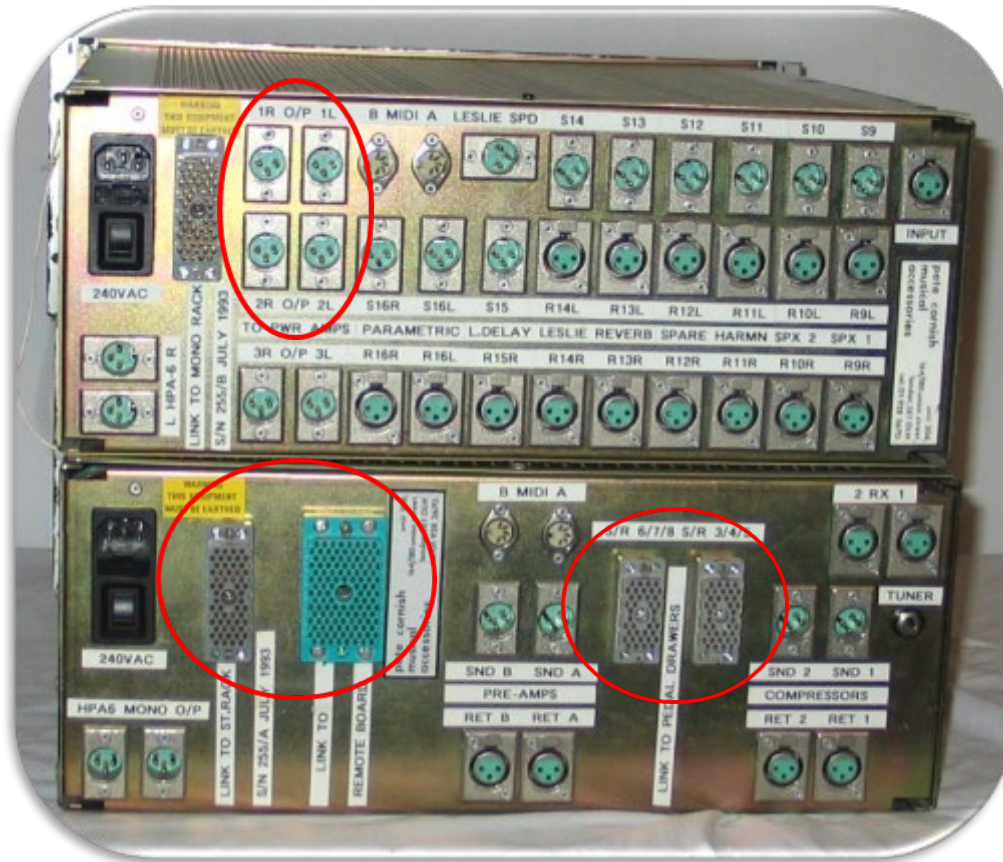

EDAC GROUP

Applications In Flight Entertainment



For use in next generation In Flight Entertainment
Now also expanding into Rail & Bus travel

RJ45 Jack
USB
D-sub

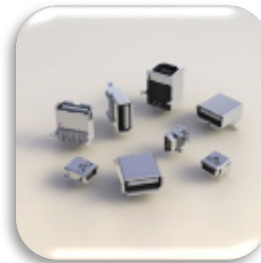

EDAC GROUP

Applications Aftermarket Auto Diagnostic Modules



EDAC GROUP

A63 Magnetic Jack Application Single Board Computers



EDAC GROUP

410 Applications - Wind Turbines

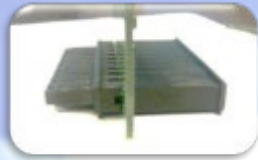

**SENVION Wind Turbine
Solutions**



EDAC GROUP

custom CONNECTORS

- Focused on solutions and problem solving
- North American Engineering team to support the custom connector business
- Low MOQ's and Quick turns
- In addition to providing solutions, a customized connector will give you a competitive edge
- Maximize your design with little or no tooling involved
- The only limit is our imagination



EDAC GROUP

custom CONNECTORS

Custom Enhanced Solution:

Modifications to existing design to improve performance & reliability while reducing costs.

Application:

Payment Solutions for ATM, Gaming, Self-Check-out and Vending Applications.

Scope:

Customer needed contacts and insulator designed with resistance to humidity

Challenge:

Redesigning the connector to conform to multi regulatory compliance requirements

Solution:

Produced superior insulator design which resulted in increased durability with vibration and shock resistance.

The connector offered better dielectric withstanding voltage and temperature cycling at a realistic price.

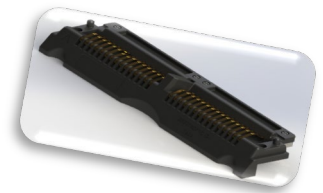

EDAC GROUP

custom CONNECTORS

Full Custom Solution:

Custom design where certain features, performance characteristics are needed or design requires major modifications to fit application and provide distinct features & benefits to the end product.

Application:

Lithium Ion Battery Pack Housing

Scope:

Custom Design Data Storage Intelligent Power Management Unit

Challenge:

Design and produce a housing for 12 Lithium Ion Batteries. The design to count for environmental conditions operational conditions and deflection forces of contacts and cover.

In addition withstand high amperage peak loads without contact degradation.

Solution:

Custom design contacts for power and signal with specified spring forces

Gold plating on active contact areas for high continuity.

Resin materials designed to mitigate excessive deflection forces on cover.

Increased durability during full power load.

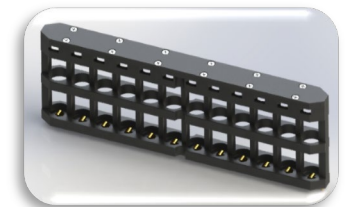

EDAC GROUP

custom CONNECTORS

Semi-Custom Variations:

Variation of standard product by taking an existing connector and modifying or enhancing areas to resolve issues or increase features. Often achieved using existing tooling or nominal low cost tooling modifications.

Application:

Aerospace Inflight Infotainment

Scope:

Provide standard high density 26 pin D-Sub Connector with 4 pins at 5amp current and 22 pins at 3amp current for signal

Challenge:

Stamped D-Sub did not meet power requirements

Machined D-Sub met power requirements but at significantly higher cost

Solution:

Designed Hybrid High Density D-Sub Connector with Machined and Stamped Contacts.

Power and Signal Combo pins at different required current ratings

67% Cost Savings achieved.

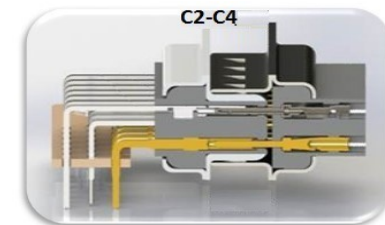

EDAC GROUP

custom CONNECTORS

Value-Added Design Solution:

Total Cost of custom solution is offset by labor and overhead cost savings producing a Net savings thereby reducing overall manufactured cost of the end product.

Application:

Transportation & Automotive Test Panels



Before

Scope:

To provide alternative design that mitigates the cost of custom tooling while achieving reduction in labor costs & improving the reliability of connections.

Challenge:

Design a stable connector to eliminate the wires and manual soldering without custom tooling a new right angle connector mold while substantially improving reliability.

Solution:

Integrated custom connector, Header, and support bracket.
Provides a ruggedized solution for long term reliability.
Achieves overall production cost savings.

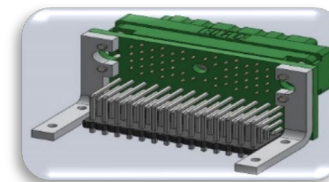

After

EDAC GROUP

custom CONNECTORS

Full Custom Solution:

Custom design where certain features, performance characteristics are needed or design requires major modifications to fit application and provide distinct features & benefits to the end product.

Application:

Enterprise wireless mobile PBX wireless phone

Scope:

Waterproof micro USB Plug for charging

Challenge:

Custom design connector to fit in a mobile PBX phone without wires.

Solution:

Custom design Micro USB over-molded splash proof connector integrating 4 pods for charging the battery while providing a seamless fit to the existing design of hand held device.



EDAC GROUP

EDAC is your number one source for innovation, ease of doing business, total cost savings and making your design concepts today a reality tomorrow!

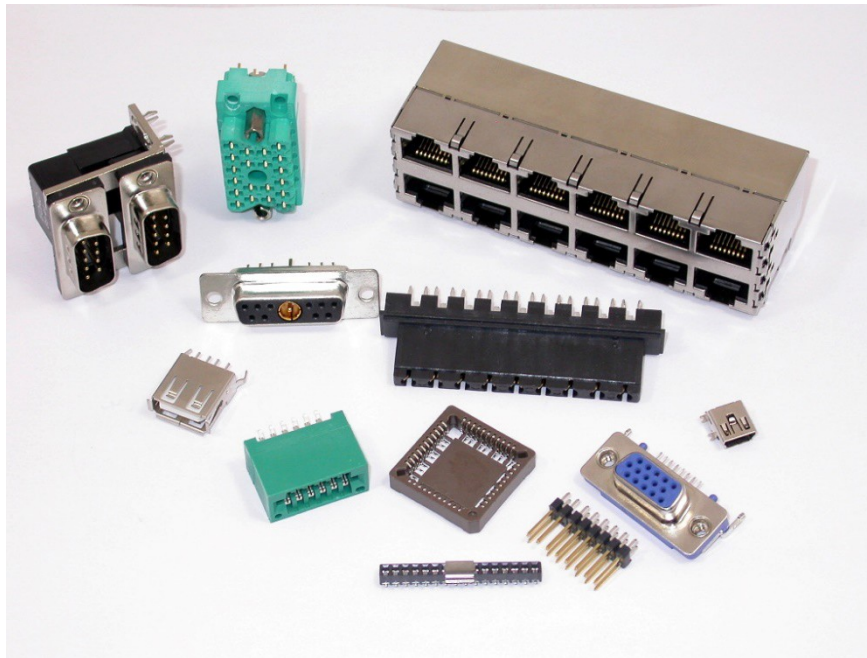

We Sell Solutions! We Manufacture Your Ideas!

Contact

ELEKTRONIK **Blume**

Christoph Haßenpflug

BLUME ELEKTRONIK DISTRIBUTION GMBH

TECCENTER 1 | 31162 | BAD SALZDETFURTH

FON:(0 50 63) 27 12-228 | FAX:(0 50 63) 27 12-12

EMAIL: C.HASSENPFUG@BLUME-ELEKTRONIK.DE

WWW.BLUME-ELEKTRONIK.DE

partnership in excellence

EDAC GROUP

Thank You!

