

DATA SHEET
SkelCap
ULTRACAPACITOR

- + Capacitance 3400 F
- + Extreme power density
- + Durable and safe aluminum casings
- + Threaded terminals
- + High cycle life >1,000,000 cycles
- + RoHS & UL810A compliant



GENERAL SPECIFICATIONS VALUE UNIT

Rated voltage V_R	2.85	V
Surge voltage V_S	3.0	V
Specific energy	7.1	Wh/kg
Nominal specific power	22	kW/kg
Practical specific power	18	kW/kg

TEMPERATURE AND LIFE VALUE UNIT

Operating temperature range		
Minimum	-40	°C
Maximum	+65	°C
Storage temperature range (uncharged)		
Minimum	-40	°C
Maximum	+50	°C
Life		
Lifetime at V_R and +65 °C	1500	Hours
Capacitance decrease 20% against rated value; 1s ESR increase 100% against rated value		
Storage life @ RT, uncharged	10	Years
Cyclelife @ RT, between V_R and $V_R/2$	1,000,000	Cycles

GENERAL VALUE UNIT

Rated capacitance	3400	F
Total (5s) DC ESR, Rated at 150A	0.23	mΩ
DC 1s ESR, rated at 50A	0.21	mΩ
DC 10ms ESR, rated at 50A	0.17	mΩ

ENERGY VALUE UNIT

Stored energy ²	3.84	Wh
Specific energy ³	7.1	Wh/kg
Energy density ⁴	9.8	Wh/L

POWER*	VALUE	UNIT
Nominal power*, calculated from 10 ms ESR (for comparison)		
Specific power, matched Impedance ⁵	22.1	kW/kg
Power density, matched Impedance ⁷	30.6	kW/L
Practical power*, calculated from 1 s ESR (for engineering)		
Power, matched impedance ⁵	9.7	kW
Specific power, matched Impedance ⁶	17.9	kW/kg
Power density, matched impedance ⁷	24.8	kW/L

STANDARDS AND CERTIFICATIONS		
Vibration Specification	ISO 16750-3 Table 12	
Shock Resistance	IEC60068-2-27 Shock Test	
Certifications	RoHS	
Standards	REACH, UL810A	

THERMAL*	VALUE	UNIT
Thermal resistance, R_{ca} , typical	3.35	°C/W
Thermal capacitance, C_{th} , typical	0.6	kJ/°C
Max continuous current, $\Delta T = 15^\circ C^8$	143	A
Max continuous current, $\Delta T = 40^\circ C^8$	233	A

PHYSICAL PARAMETERS	VALUE	UNIT
Mass. Typical	0.54	kg
Volume	0.39	L
Diameter	60	mm
Length	138	mm

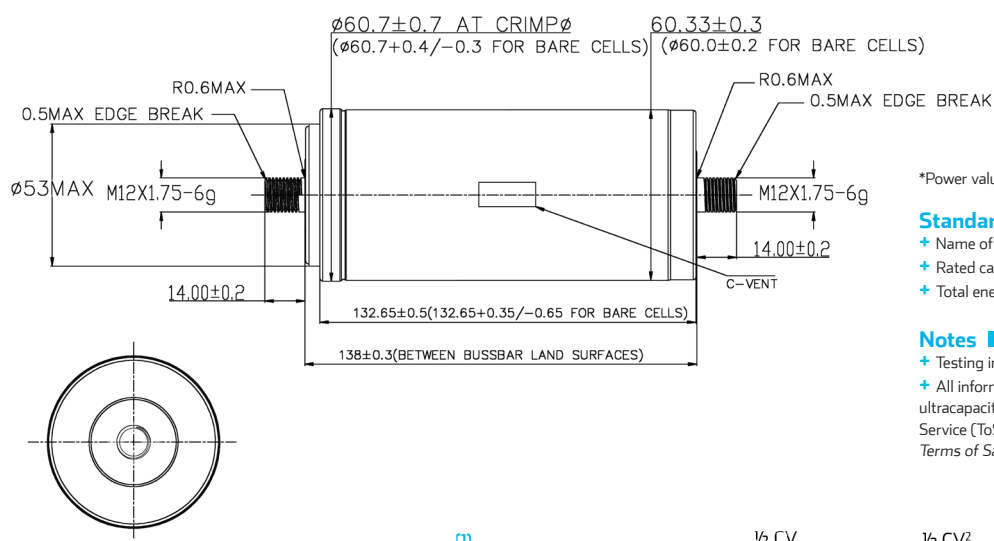

*Power values calculated using DC 10ms ESR ≈ AC 100Hz.

Standard markings

- + Name of manufacturer, part number, serial number, rated voltage
- + Rated capacitance, negative and positive terminals, warning marking
- + Total energy in watt-hours

Notes

- + Testing instructions available on www.skeletontech.com
- + All information provided on this data sheet and all subsequent ultracapacitors sales and testing are subject to Standard Terms of Service (ToS) available on www.skeletontech.com, document *General Terms of Sale for Skeleton Technologies OÜ*.

$$\begin{aligned}
 (1) \text{ Maximum peak current (1 sec)} &= \frac{\frac{1}{2} CV}{C \times ESR + 1s} & (2) E_{\text{stored}} &= \frac{\frac{1}{2} CV^2}{3,600} & (3) E_{\text{max}} &= \frac{\frac{1}{2} CV^2}{3,600 \times \text{mass}} & (4) E_{\text{max}} &= \frac{\frac{1}{2} CV^2}{3,600 \times \text{volume}} \\
 (5) P_{\text{max}} &= \frac{V^2}{4 \times ESR} & (6) P_{\text{max}} &= \frac{V^2}{4 \times ESR \times \text{mass}} & (7) P_{\text{max}} &= \frac{V^2}{4 \times ESR \times \text{volume}} & (8) I_{\text{max}} &= \sqrt{\frac{\Delta T}{ESR \times R_{\theta}}}
 \end{aligned}$$