

Data Sheet

Customer:

Product: Automotive Grade Low Ohm (Metal Strip) Chip Resistor –
LRP..A Series

Size: 1206 / 2512

Issued Date: 15-Nov-21

Edition: REV.A1



VIKING TECH CORPORATION
光頡科技股份有限公司
No.70 Guangfu N. Rd., Hukou
Township, Hsinchu County 303,
Taiwan

TEL:886-3-5972931
FAX:886-3-5972935•886-3-5973494
E-mail:sales@viking.com.tw

VIKING TECH CORPORATION KAOHSIUNG BRANCH
光頡科技股份有限公司高雄分公司
No.248-3, Sin-Sheng Rd., Cian-Jhen Dist., Kaohsiung,
806, Taiwan

TEL:886-7-8217999
FAX:886-7-8228229
E-mail:sales@viking.com.tw

VIKING ELECTRONICS (WUXI) CO., LTD.
光頡電子(無錫)有限公司
No.22 Xixia Road, Machinery & Industry Park,
National Hi-Tech Industrial Development Zone
of Wuxi, Wuxi, Jiangsu Province, China
Zip Code:214028
TEL:86-510-85203339
FAX:86-510-85203667•86-510-85203977
E-mail:china@viking.com.tw

Produced by (QC)	Checked (QC)	Approved by (QC)	Prepared by (Sales)	Accepted by (Customer)
15-Nov-21	15-Nov-21	15-Nov-21		
Susan Huang	J.C. Liu	J.C. Liu		

Automotive Grade Low Ohm (Metal Strip) Chip Resistor- LRP..A Series

■ Features

- Low TCR down to ± 25 PPM/ $^{\circ}$ C
- Customized resistance available
- Low inductance < 5nH
- AEC-Q200 Compliance
- Sulfur resistance unaffected by sulfur environments
- Lead-free and RoHS compliant
- 100% CCD inspection



■ Applications

- NB (for Power Management)
- MB (for Power Management)
- SWPS (DC-DC Converter, Charger, Adaptor)
- Monitor (for Power Management)
- Industrial / Power supply
- Automotive

■ Construction

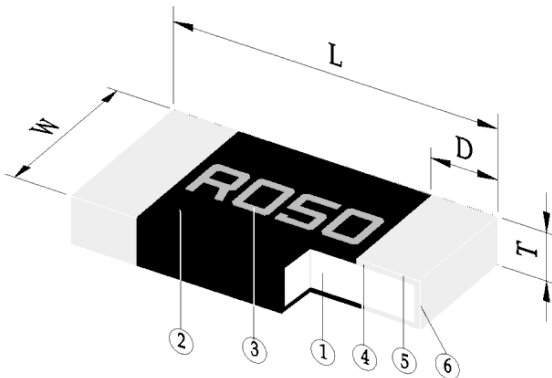

① Alloy Plate	④ Internal Electrode
② Overcoat	⑤ Barrier Layer
③ Marking	⑥ Solder Plating

■ Dimensions

Type	Size (Inch)	L (mm)	W (mm)	T (mm)	D (mm)	Weight (g) (1000pcs)
LRP06	1206	3.15 \pm 0.10	1.45 \pm 0.10	0.55 \pm 0.10	0.55 \pm 0.15	10.5
LRP12	2512	6.40 \pm 0.25	3.20 \pm 0.25	0.70 \pm 0.20	0.90 \pm 0.30	52.6

■ Part Numbering

LRP	12	F	T	D	S	R015	A
Product Type	Dimensions (LxW)	Resistance Tolerance	Packaging Code	TCR (PPM/ $^{\circ}$ C)	Power Rating	Resistance	Marking
	06: 1206 12: 2512	D: \pm 0.5% F: \pm 1% J: \pm 5%	T: Taping Reel	C: \pm 25 D: \pm 50 W: \pm 75 E: \pm 100	R: 3W S: 2W T: 1W	R015: 0.015 Ω R050: 0.05 Ω	A: Automotive Grade

Derating Curve

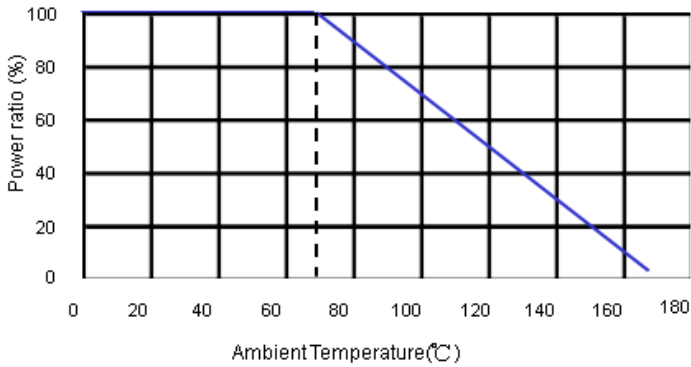

Electrical Specifications

Type	Item	Power Rating at 70°C	Operating Temp. Range	Resistance Range (mΩ)			TCR (PPM/°C)
				±0.5%	±1%	±5%	
LRP06 (1206)		1W	-55 ~ +170°C	8, 10, 12, 15, 20, 25, 30, 33, 40			±50
				3, 4, 5, 7, 8, 10, 12, 15, 20, 25, 30, 33, 40			±75 ±100
LRP12 (2512)		2W, 3W	-55 ~ +170°C	3, 4, 5, 6, 7, 18, 20, 22, 25, 30, 33, 35, 39, 40, 47, 50, 60, 68, 70, 75, 80, 82, 90, 91, 100, 120, 150, 180, 200			±25
				3, 4, 5, 6, 7, 8, 9, 10, 12, 15, 18, 20, 22, 25, 30, 33, 35, 39, 40, 47, 50, 60, 68, 70, 75, 80, 82, 90, 91, 100, 120, 150, 180, 200			±50 ±75

Operating Current = $\sqrt{P/R}$, Operating Voltage = $\sqrt{P \cdot R}$

■ Viking is capable of manufacturing the optional spec based on customer's requirement.

Soldering Condition

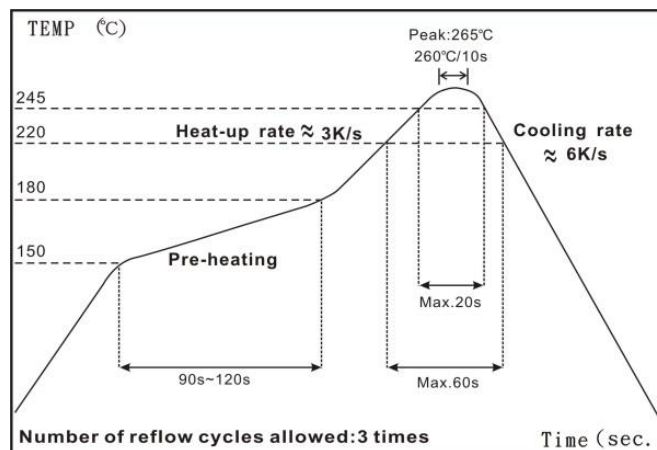

IR Reflow Soldering

(1) Time of IR reflow soldering at maximum temperature point 260°C : 10s

■ Environmental Characteristics

Item	Requirement	Test Method
Temperature Coefficient of Resistance (T.C.R.)	As Spec.	IEC60115-1 4.8 JIS-C-5201-1 4.8 +25°C ~125°C, 25°C is the reference temperature
Short Time Overload	±1.0%	IEC60115-1 4.13 JIS-C-5201-1 4.13 5*rated power for 5 seconds
Insulation Resistance	≥10G	IEC60115-1 4.6 JIS-C-5201-1 4.13 100V DC for 1 minute
Endurance	±1.0%	IEC60115-1 4.25 JIS-C-5201-1 4.25.1 70±2°C, rated power for 1000 hrs with 1.5 hrs "ON" and 0.5 hr "OFF"
Biased Humidity	±1.0%	MIL-STD-202 Method 103 1000 hrs 85°C/85%RH 10% of operating power
High Temperature Exposure	±1.0%	MIL-STD-202 Method 108 at +170°C for 1000 hrs
Board Flex	±1.0%	AEC-Q200-005 Bending once for 60 seconds 3mm
Solderability	95% min. coverage	JIS-C-5201-1 4.17 IEC-60115-1 4.17 245±5°C for 3 seconds
Resistance to Soldering Heat	±0.5%	JIS-C-5201-1 4.18 IEC-60115-1 4.18 260±5°C for 10 seconds
Temperature Cycling	±1.0%	JESD22 Method JA-104 -55°C to +125°C, 1000 cycles
Low Temperature Storage	±1.0%	IEC60115-1 4.23.4 JIS-C-5201-1 4.23.4 at -55°C for 2 hrs
Mechanical Shock	±(0.25%+0.05Ω)	MIL-STD-202 Method 213 Wave Form: Tolerance for half sine shock pulse. Peak value is 100g's. Normal duration (D) is 6.
Vibration	±(0.5%+0.05Ω)	MIL-STD-202 Method 204 5 g's for 20 min., 12 cycles each of 3 orientations, 10-2000 Hz
ESD	±(3%+0.05Ω)	AEC-Q200-002 Human body model: 2KV
Resistance to Solvents	No visible damage on appearance and marking.	MIL-STD-202 Method 215 Add Aqueous wash chemical - OKEM Clean or equivalent. Do not use banned solvents.
Terminal Strength	No broken	AEC-Q200-006 Force of 1.8kg for 60 seconds.
Flammability	No ignition of the tissue paper or scorching or the pinewood board	UL-94 V-0 or V-1 are acceptable. Electrical test not required.

RCWV(Rated Continuous Working Voltage)= $\sqrt{P \cdot R}$ or Max. Operating Voltage whichever is lower.

■ Storage Temperature: 15~28°C; Humidity < 80%RH

■ Shelf Life: 2 years from production date.

Automotive Grade Low Ohm (Metal Strip) Chip Resistor

■ Packaging

Reel Specifications & Packaging Quantity

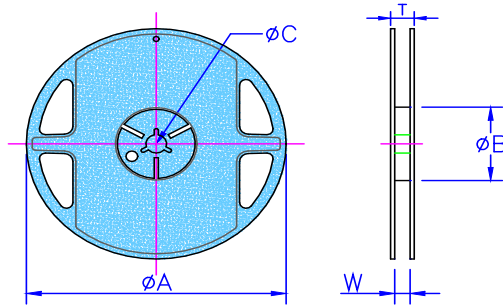

Type	Resistance (mΩ)	Packaging Quantity	Tape Width	Reel Diameter	ΦA (mm)	ΦB (mm)	ΦC (mm)	W (mm)	T (mm)	
LRP06	3~40	Paper	5K	8mm	7 inch	178.5±1.5	60 ^{+1/-0}	13.0±0.2	9.0±0.5	12.5±0.5
LRP12	4~200	Embossed	4K	12mm	7 inch	178.5+/-1.5	60±1.0	13.0±0.5	13.0±1.0	15.5±0.5
LRP12	3	Embossed	2K	12mm	7 inch	178.5+/-1.5	60±1.0	13.0±0.5	13.0±1.0	15.5±0.5

Embossed Plastic Tape Specifications

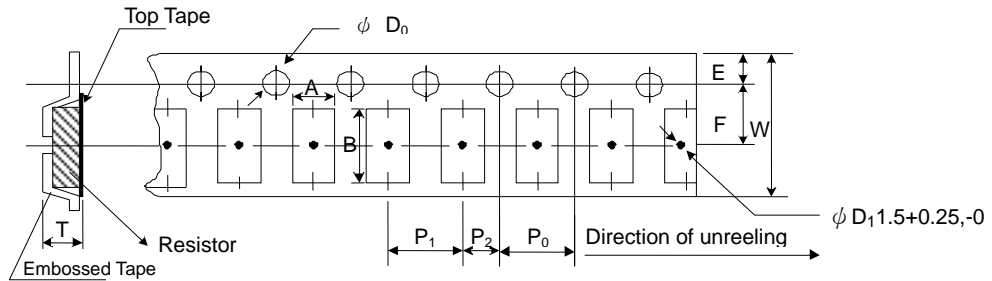

Type	A (mm)	B (mm)	W (mm)	E (mm)	F (mm)	P ₀ (mm)	P ₁ (mm)	P ₂ (mm)	ΦD ₀ (mm)	T (mm)
LRP12	3.50±0.10	6.70±0.10	12.0±0.30	1.75±0.10	5.5±0.05	4.00±0.10	4.00±0.10	2.00±0.05	1.50+0.1, -0	1.20+0
LRP12 (3mΩ)	3.50±0.10	6.70±0.10	12.0±0.30	1.75±0.10	5.5±0.05	4.00±0.10	4.00±0.10	2.00±0.05	1.50+0.1, -0	1.45±0.2

Paper Tape Specifications

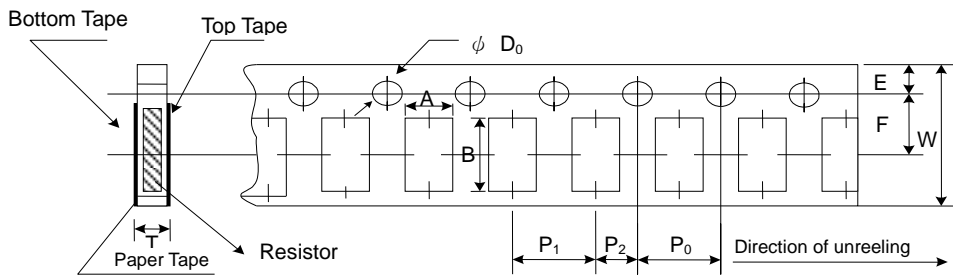

Type	A (mm)	B (mm)	W (mm)	E (mm)	F (mm)	P ₀ (mm)	P ₁ (mm)	P ₂ (mm)	ΦD ₀ (mm)	T (mm)
LRP06	1.90±0.10	3.50±0.20	8.0±0.20	1.75±0.10	3.50±0.05	4.00±0.10	4.00±0.05	2.00±0.05	1.50+0.1,-0	0.85±0.10

■ Recommend Land Pattern

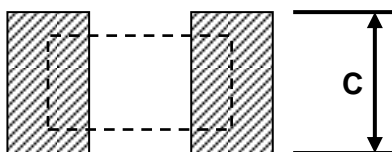

Type	A (mm)	B (mm)	C (mm)
LRP06	1.50	1.40	1.70
LRP12	4.00	2.00	3.50

* FR4 copper board, 100μm of copper pad thickness

REVISION HISTORY

REVISION	DATE	CHANGE NOTIFICATION	DESCRIPTION
Version A	Jul 20, 2021	-	- First issue of this specification
Version A1	Nov 15, 2021	-	- Increase the shelf life description